

4

3

2

1

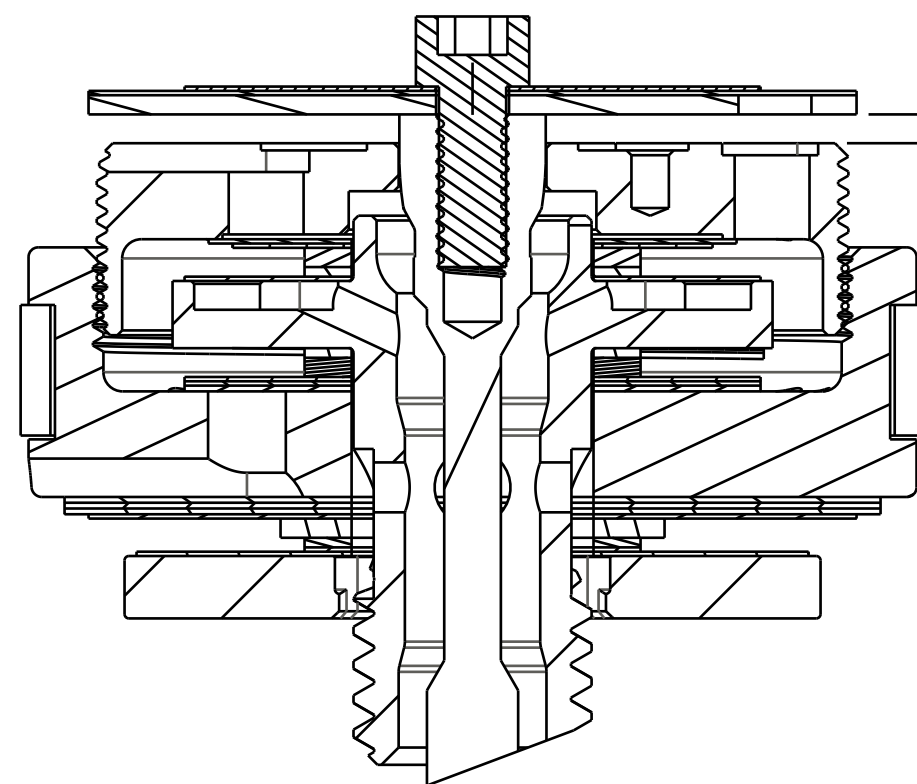

805-02-031-KIT  
Piston Assembly: 2016 Float DPS, [Ø 0.940 Bore] w/ Glyde Ring

TORQUE:  
60+/-5 IN-LB  
CUSTOM SOCKET 398-00-637

210-10-120  
Piston Bolt: Float DPS w/ Check 2mm Cross Holes [1/4-28 X 5/8 Hex]

222-01-316  
Piston: Lockout, Float DPS V3 [.200 TLG, M20 X 0.5] 416SS

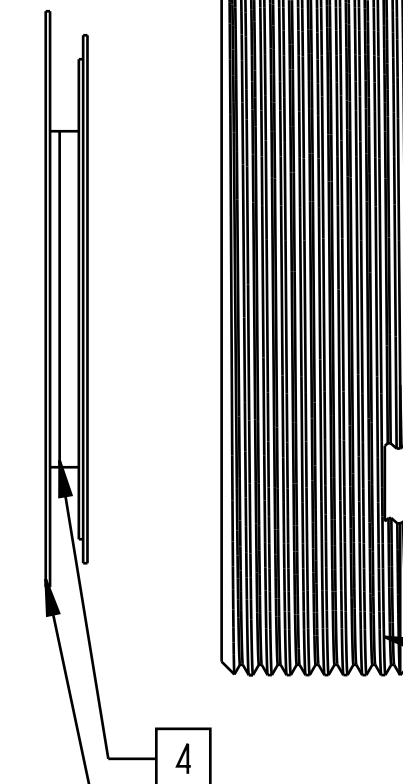
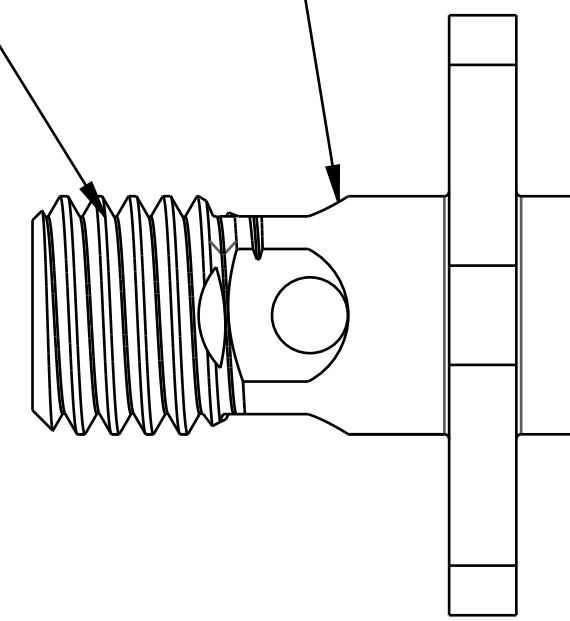
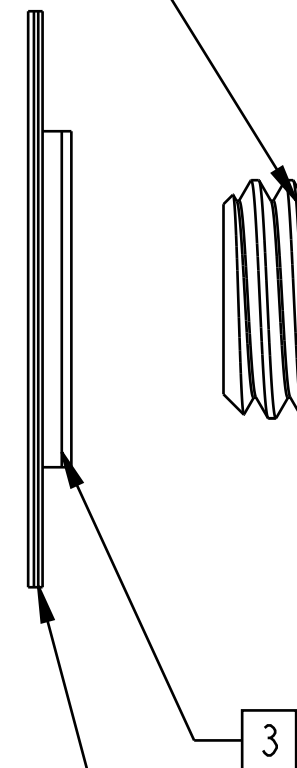
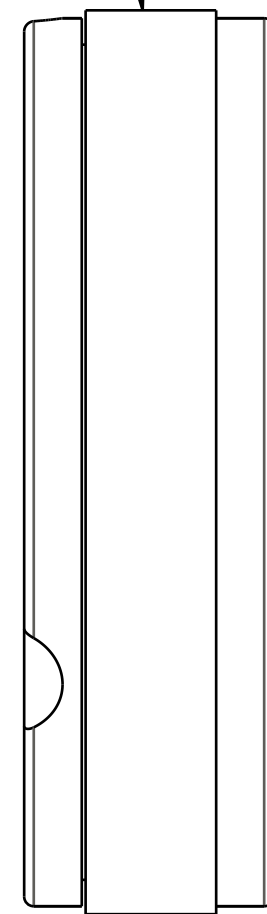
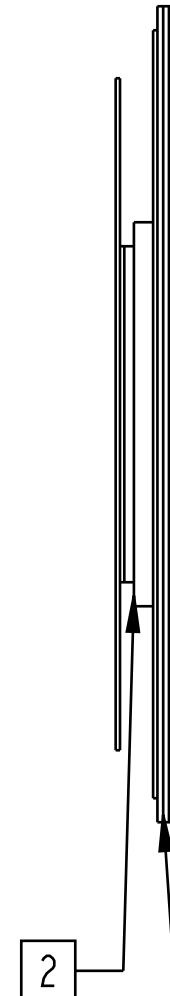

TORQUE:  
22+/-2 IN-LB  
CUSTOM SOCKET 398-00-638

210-10-098  
FLOAT MY2013 Check Piston [.700 OD X .252 ID X .065 TH] Round CNC, SS

805-05-104-KIT  
Valve Stack Assy: 2018 Float DPS, Digressive Compression Firm, DCF

805-05-301-KIT  
Valve Stack Assy: 2018 Float DPS, Digressive Rebound Medium, DRM

805-05-201-KIT  
Valve Stack Assy: 2018 Float DPS, Lockout Firm, CMF

- NOTES: (UNLESS OTHERWISE SPECIFIED)
1. SHOCK SHOULD HAVE 12-15 REBOUND CLICKS
  - [2] SPACERS MAY BE ADDED OR REMOVED TO ADJUST NUMBER OF REBOUND CLICKS.
  - [3] SPACERS MAY BE ADDED OR REMOVED TO ADJUST NUMBER OF REBOUND CLICKS.
  - [4] SPACERS MAY BE ADDED OR REMOVED TO ADJUST LOCKOUT PLATE LIFT.
  5. REFER TO INDIVIDUAL COMPRESSION, REBOUND, OR LOCKOUT VALVE STACK ASSEMBLY DRAWING FOR SPACER DETAILS AND TOTAL STACK HEIGHT MEASUREMENT.
  - [6] USE .030-.047 LIFT SPEC FROM CLOSED TO OPEN FOR REMOTES WITH 210-30-090 OR 210-30-115 CAMS (TREK)

PROPRIETARY -  
THIS DOCUMENT CONTAINS CONFIDENTIAL, PROPRIETARY INFORMATION  
THAT IS FOX PROPERTY. DO NOT DISCLOSE TO OR DUPLICATE  
FOR OTHERS EXCEPT AS AUTHORIZED BY FOX.

<b>FOX Factory, Inc.</b> 130 Hangar Way, Watsonville, CA 95076 USA Ph 831-768-1100 Fax 831-768-9312	
TITLE <b>Valving Assy: 2018 Float DPS, R/C, DCF, DRM, CMF [.940 Bore]</b>	
SIZE <b>C</b>	DWG. NO. <b>807-06-225-KIT</b>
PLOT SCALE 2.00:1	SHEET 1 OF 1

4

3

2

ProE ASSEM