

4

3

2

1

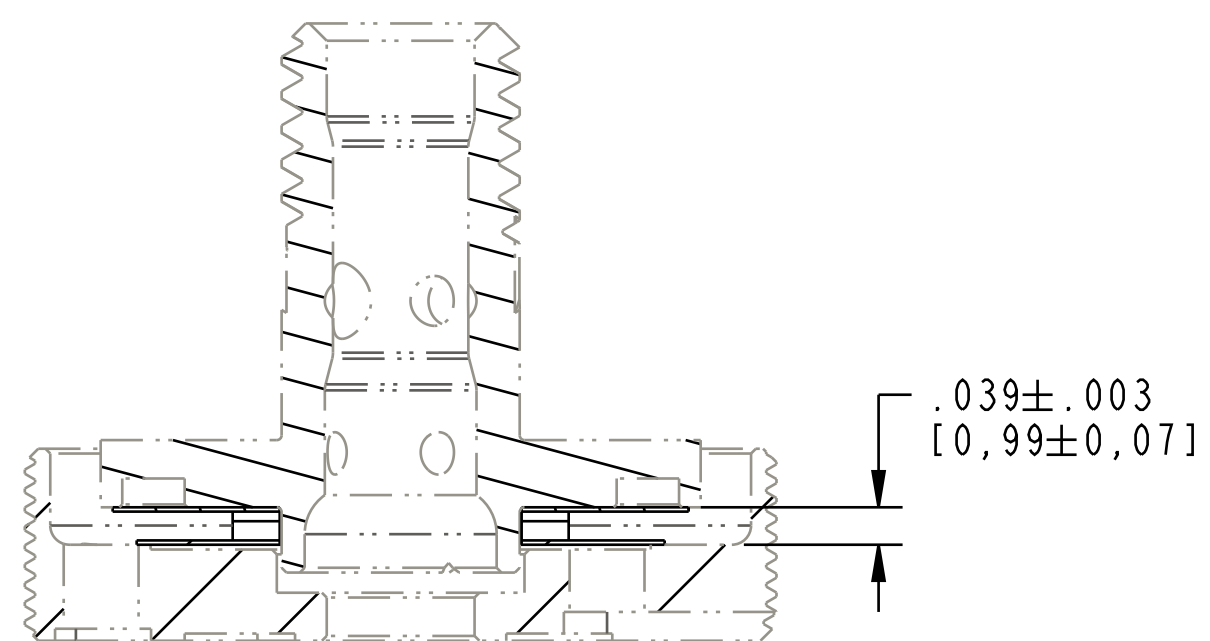

SECTION B-B  
SCALE 5.000

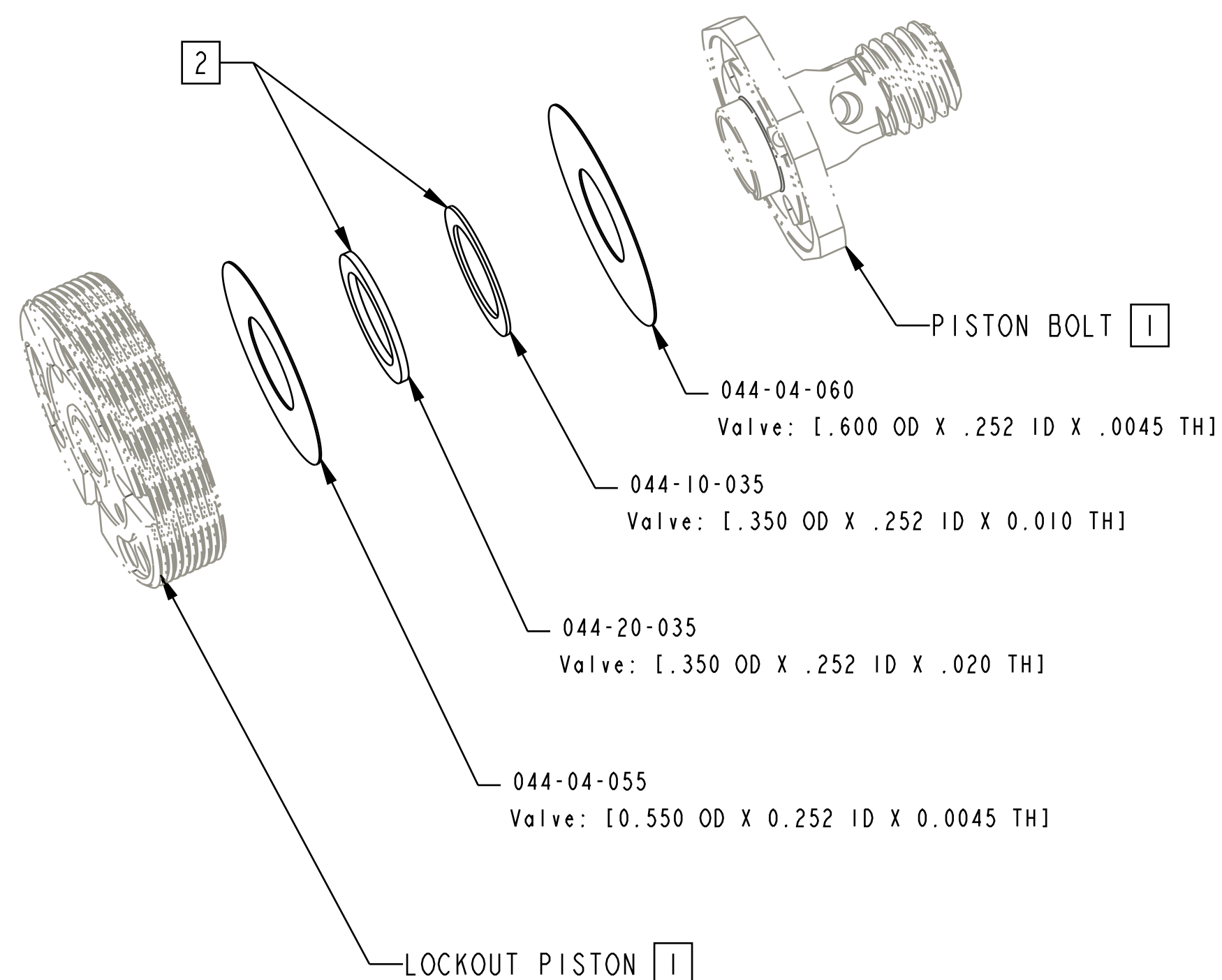

NOTES: UNLESS OTHERWISE SPECIFIED

[1] PISTON AND PISTON BOLT PARTS SHOWN FOR ORIENTATION PURPOSES. MAY NOT REPRESENT ACTUAL PART GEOMETRY

[2] 1 SPACER MAY BE REMOVED. 1 OR 2 SPACERS MAY BE ADDED TO ADJUST LOCKOUT PLATE LIFT. MIN SPACING .010" MATCH OUTSIDE DIAMETER OF ADJACENT SPACER.

- PROPRIETARY -  
THIS DOCUMENT CONTAINS CONFIDENTIAL, PROPRIETARY INFORMATION THAT IS FOX PROPERTY. DO NOT DISCLOSE TO OR DUPLICATE FOR OTHERS EXCEPT AS AUTHORIZED BY FOX.

**FOX** **FOX Factory, Inc.** Ph 831-768-1100  
130 Hangar Way, Watsonville, CA 95076 USA Fax 831-768-9312

TITLE  
Valve Stack Assy: 2018 Float DPS,  
Lockout Light, CML

SIZE DWG. NO. **805-05-200-KIT**

PLOT SCALE 3.00:1 SHEET 1 OF 1

4

3

2

ProE ASSEM