

PROPRIETARY
 THIS DOCUMENT CONTAINS CONFIDENTIAL, PROPRIETARY INFORMATION THAT IS FOX PROPERTY. DO NOT DISCLOSE TO OR DUPLICATE FOR OTHERS EXCEPT AS AUTHORIZED BY FOX.

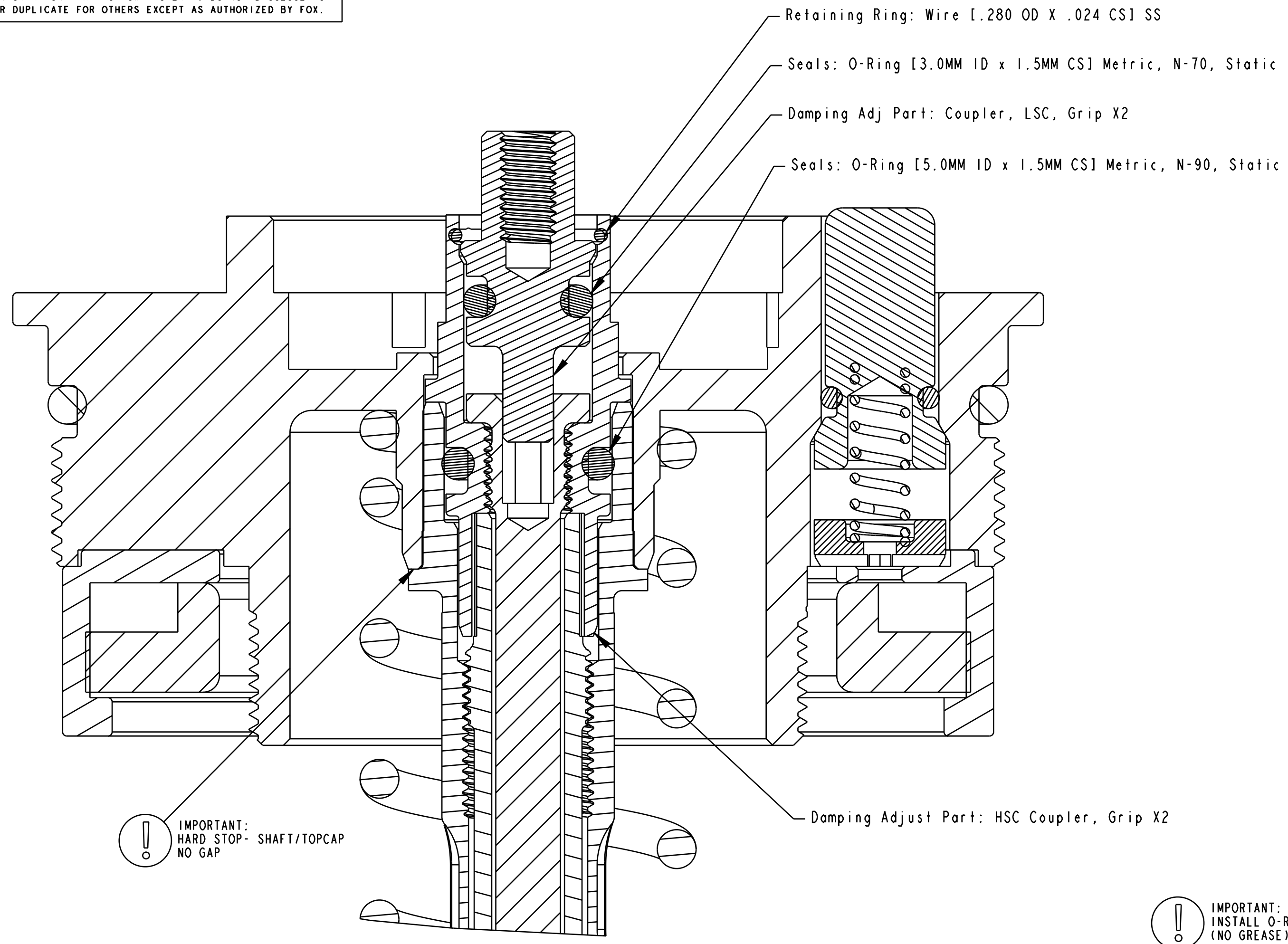

IMPORTANT:
 HARD STOP- SHAFT/TOPCAP
 NO GAP

IMPORTANT:
 INSTALL O-RING DRY
 (NO GREASE)

IMPORTANT:
 ENSURE SPRING SNAPS ON MATING PART
 (FULLY SEATED)

DETAIL Y
 SCALE 6:1

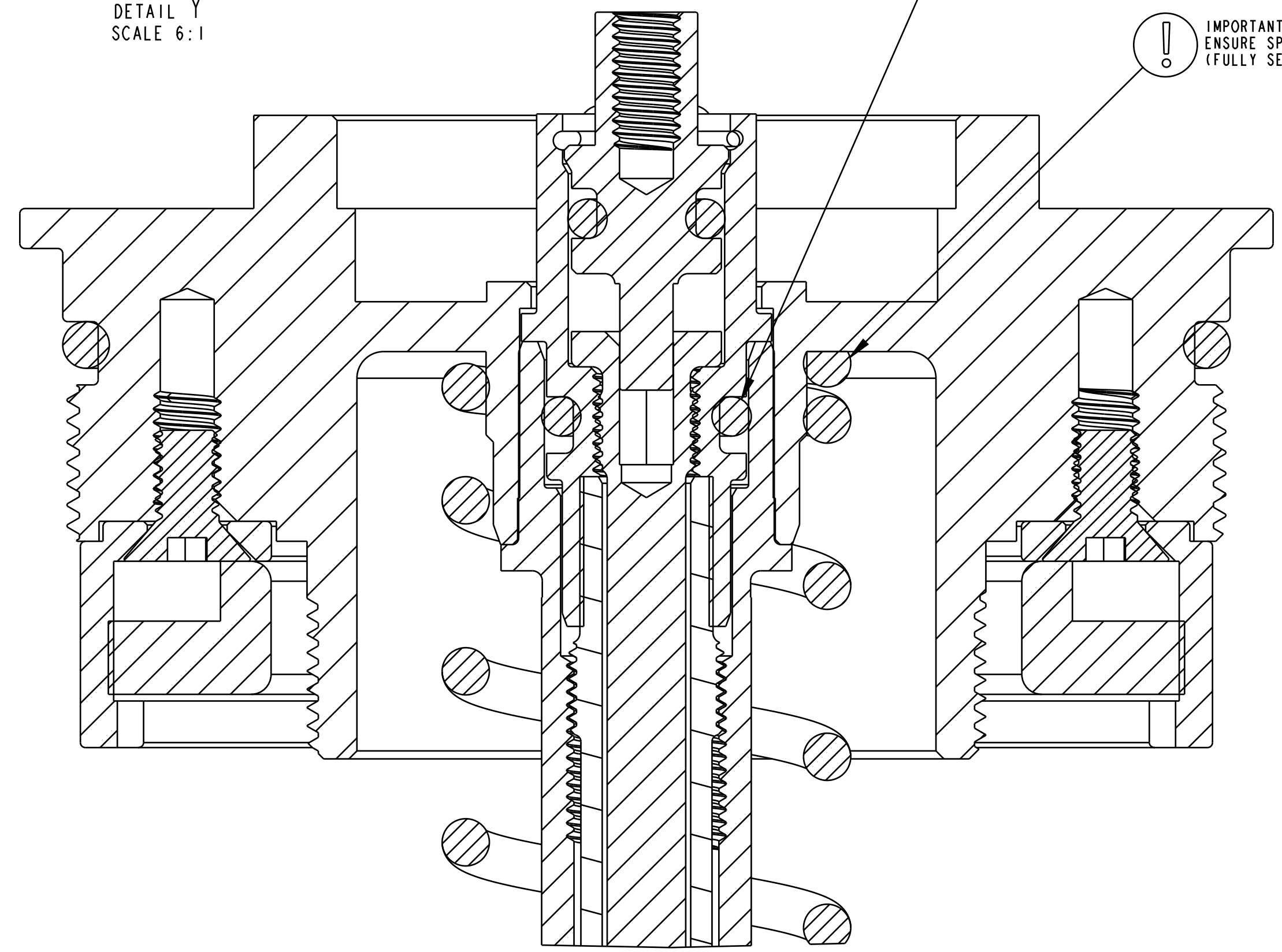

DETAIL Z
 SCALE 6:1

DETAIL X
 SCALE 6:1