

IMPORTANT:
NOTE ORIENTATION OF
FIRM MODE VALVE STACK ASSY

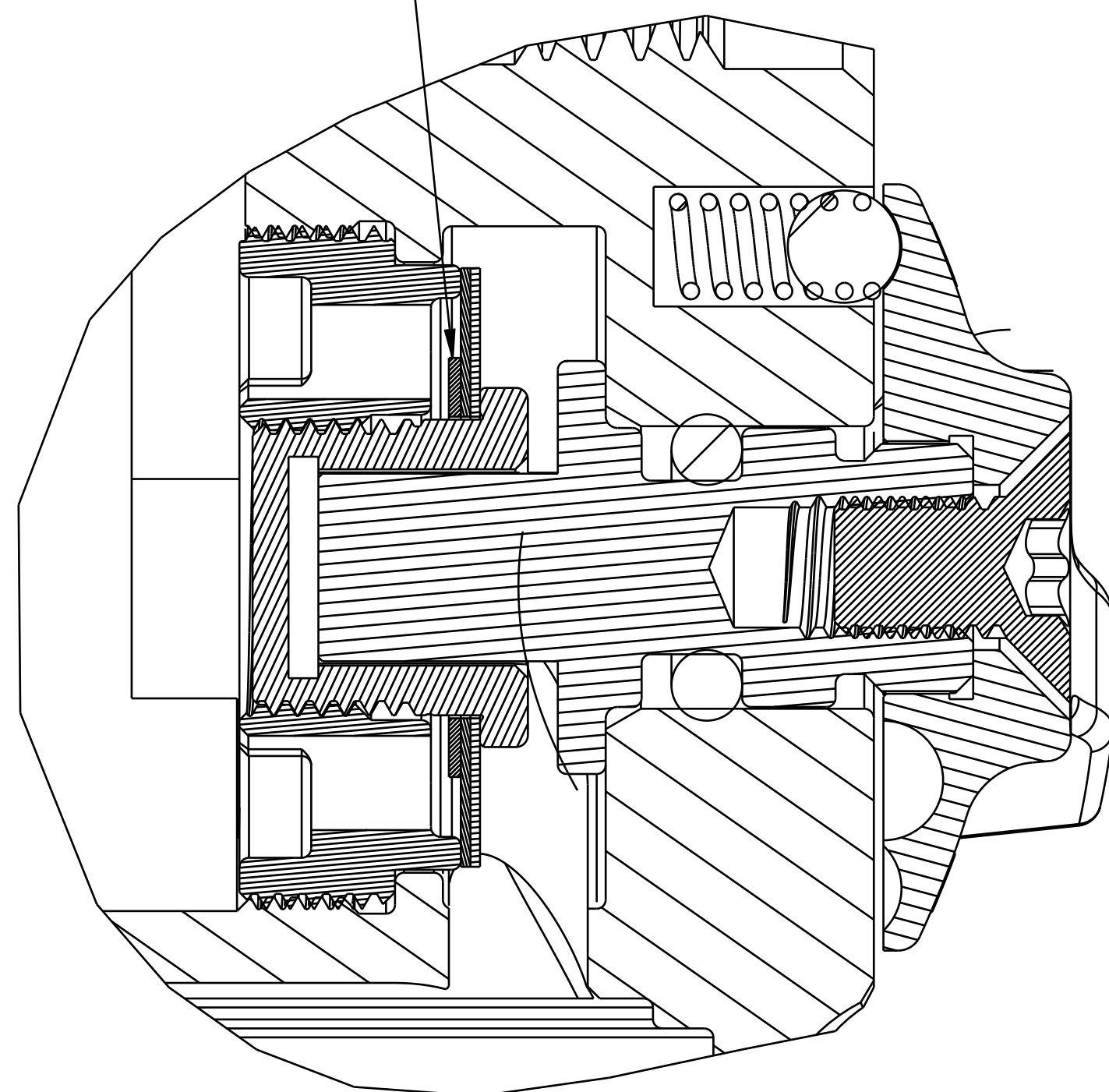

SECTION A-A
SCALE 8:1

NOTES:

1. INSTALL LEVER IN MOST CLOCKWISE POSITION, TURNING ADJUSTER SHAFT SLIGHTLY COUNTER-CLOCKWISE IF NECESSARY.

PROPRIETARY
THIS DOCUMENT CONTAINS CONFIDENTIAL, PROPRIETARY INFORMATION
THAT IS FOR PROPERTY. DO NOT DISCLOSE TO OR DUPLICATE
FOR OTHERS EXCEPT AS AUTHORIZED BY FOX.

FOX FOX Factory, Inc. Ph 831-768-1100
130 Hangar Way, Watsonville, CA 95076 USA Fax 831-768-9312

TITLE
Eyelet Sub Assy: Firm Mode Adjust,
2024 Live Valve Neo, Shock, FLOAT X

SIZE DWG. NO. 808-17-528-KIT
D | PLOT SCALE 2:1 | SHEET 1 OF 1