

4

3

2

1

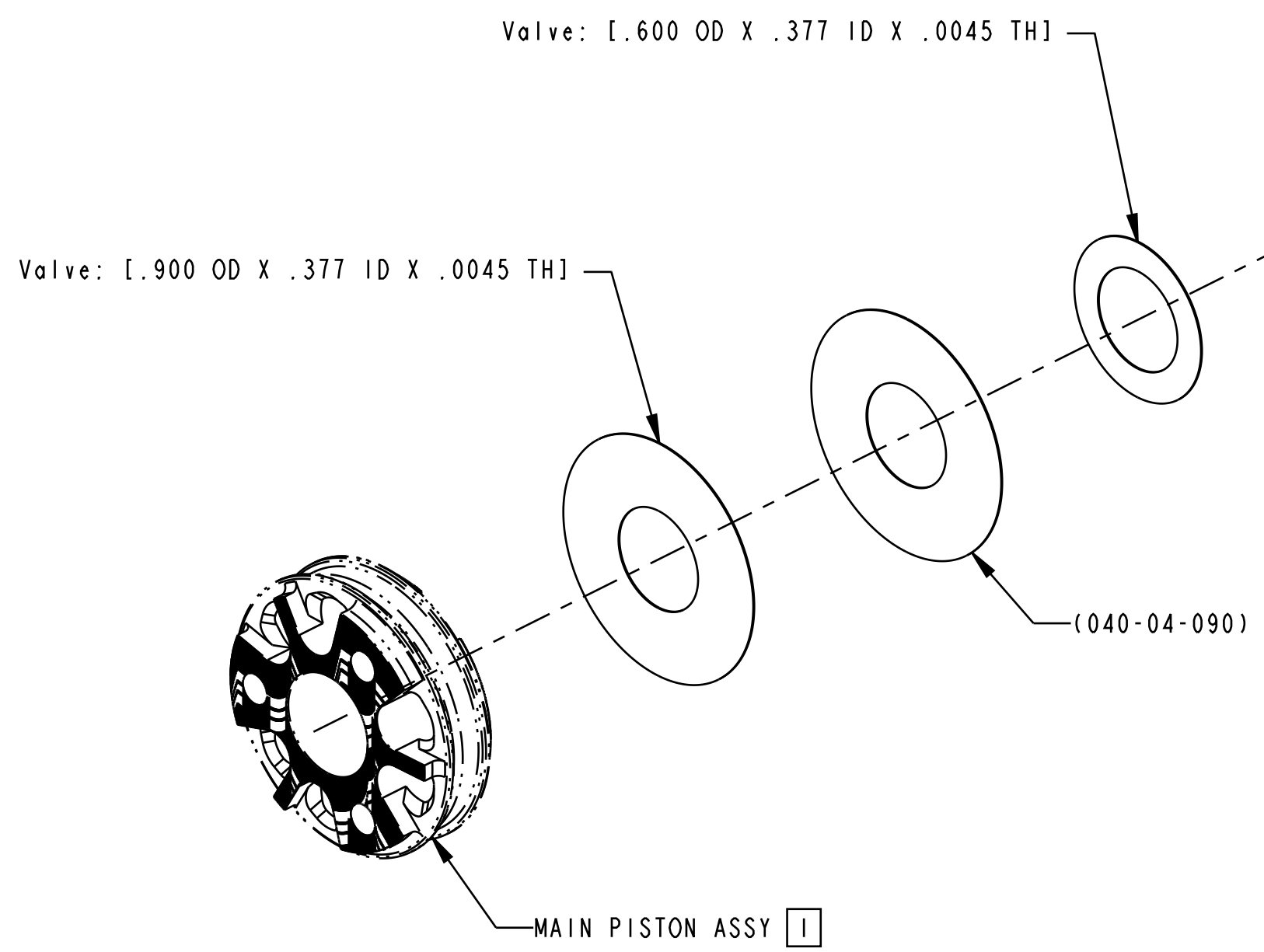
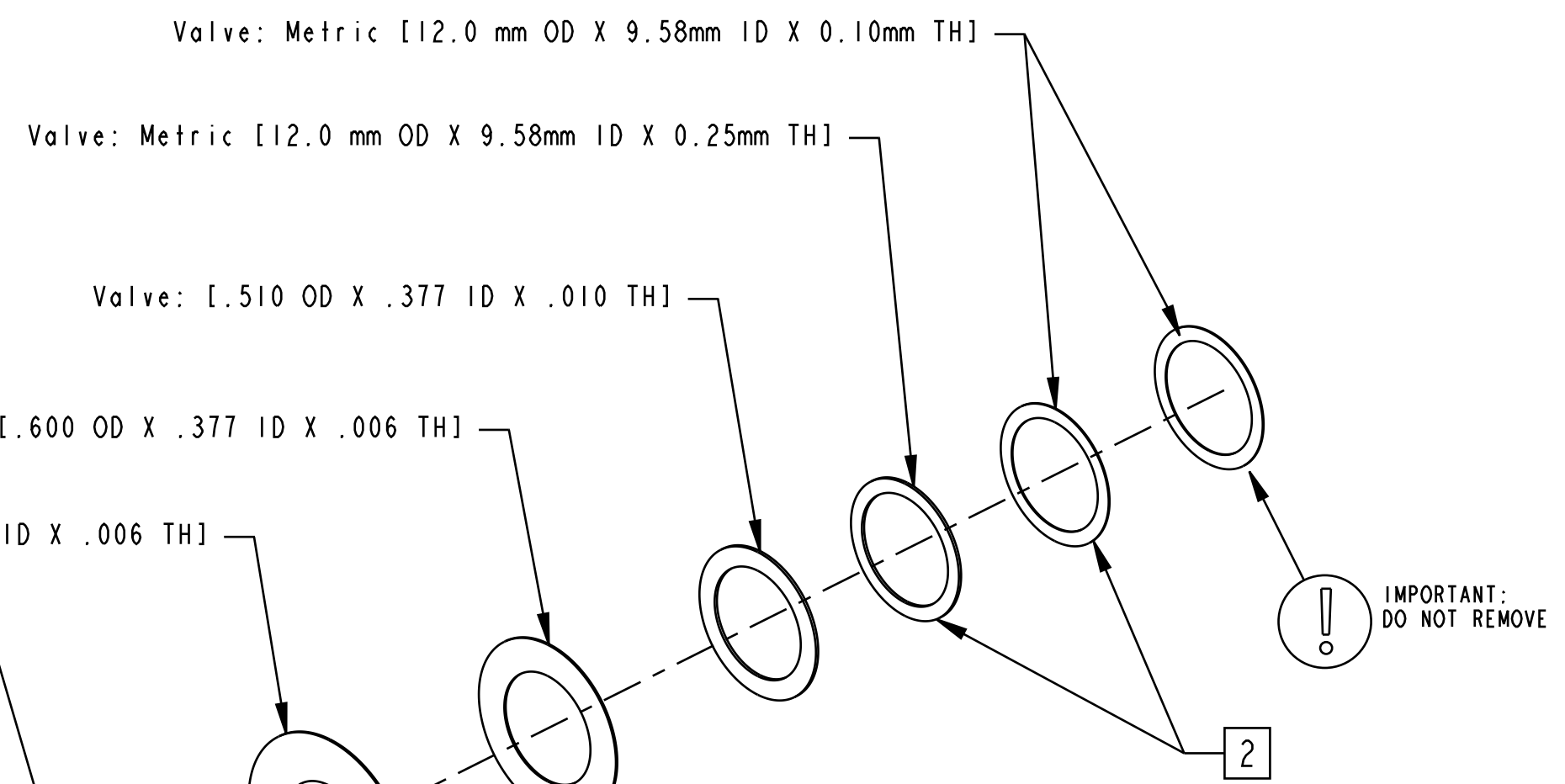
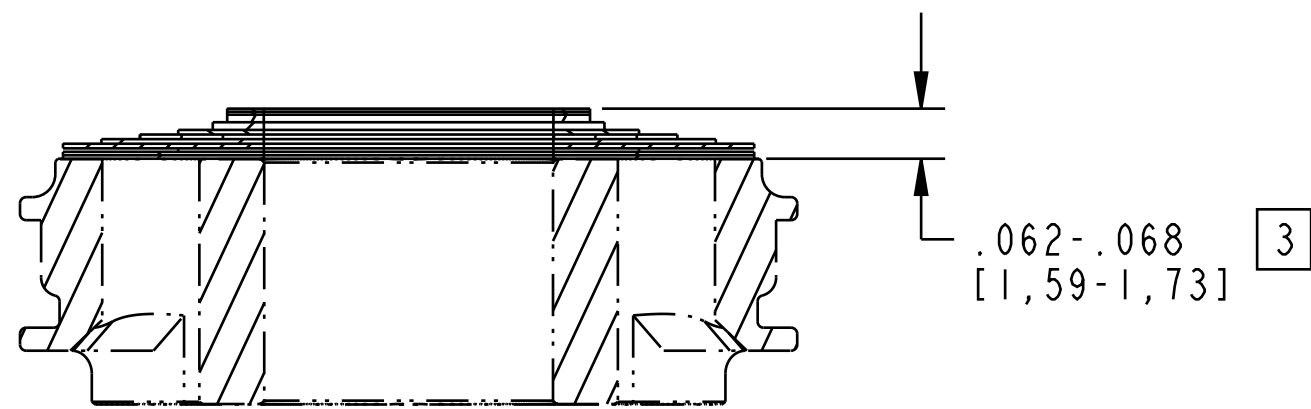

MANUFACTURING NOTES:

- 1 MAIN PISTON ASSEMBLY SHOWN FOR ORIENTATION PURPOSES. NOTE PROPER ORIENTATION OF PISTON--SEE VALVING ASSEMBLY DRAWING FOR DETAILS. IMAGE SHOWN MAY NOT REPRESENT ACTUAL PART GEOMETRY.
- 2 INDICATED SPACERS MAY BE ADDED OR REMOVED TO ADJUST NUMBER OF REBOUND CLICKS.
- 3 DIMENSION APPLIES TO VALVE STACK AS SHOWN.

DESIGN ENGINEERING AND PRODUCT PERFORMANCE NOTES:

- 4. COMPRESSION VALVE STACK NOMINAL MINIMUM THICKNESS (NMT): 0.051 [1,31]

- PROPRIETARY -
THIS DOCUMENT CONTAINS CONFIDENTIAL, PROPRIETARY INFORMATION
THAT IS FOX PROPERTY. DO NOT DISCLOSE TO OR DUPLICATE
FOR OTHERS EXCEPT AS AUTHORIZED BY FOX.

FOX		FOX Factory, Inc.		Ph 831-768-1100
130 Hangar Way, Watsonville, CA 95076 USA				Fax 831-768-9312
TITLE Valve Stack Assy: 2025 FLOAT X & DHX, CS40, Comp Split Stack, FP, .051 NMT				
SIZE	DWG. NO.	805-05-713-KIT		
C				
PLOT SCALE	2:1			SHEET 1 OF 1

4

3

2

1

ProE ASSEM