

4

3

2

1

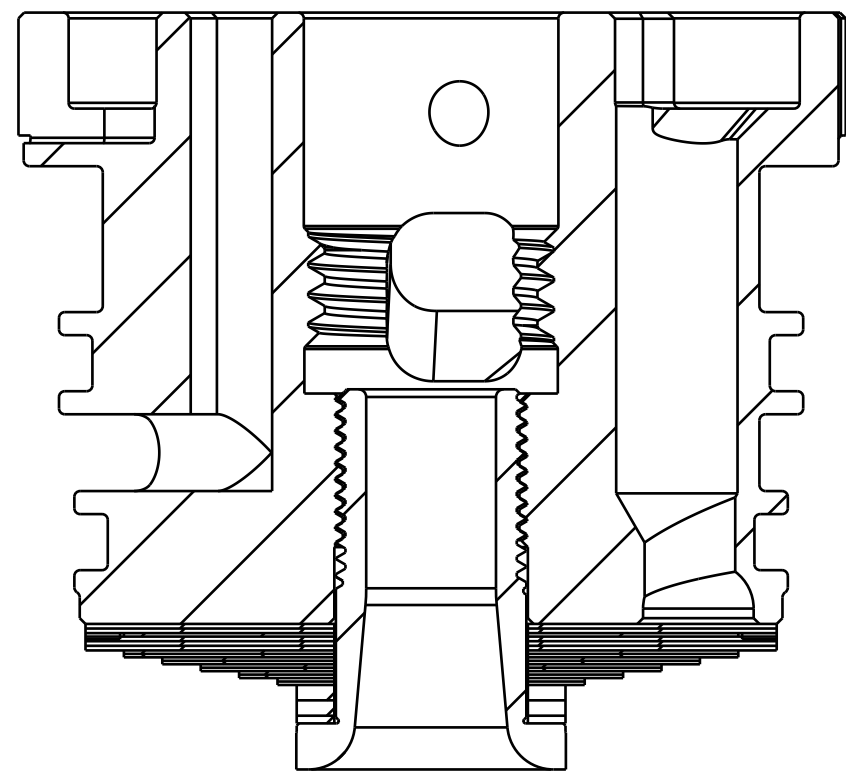

SECTION A-A
SCALE 4:1

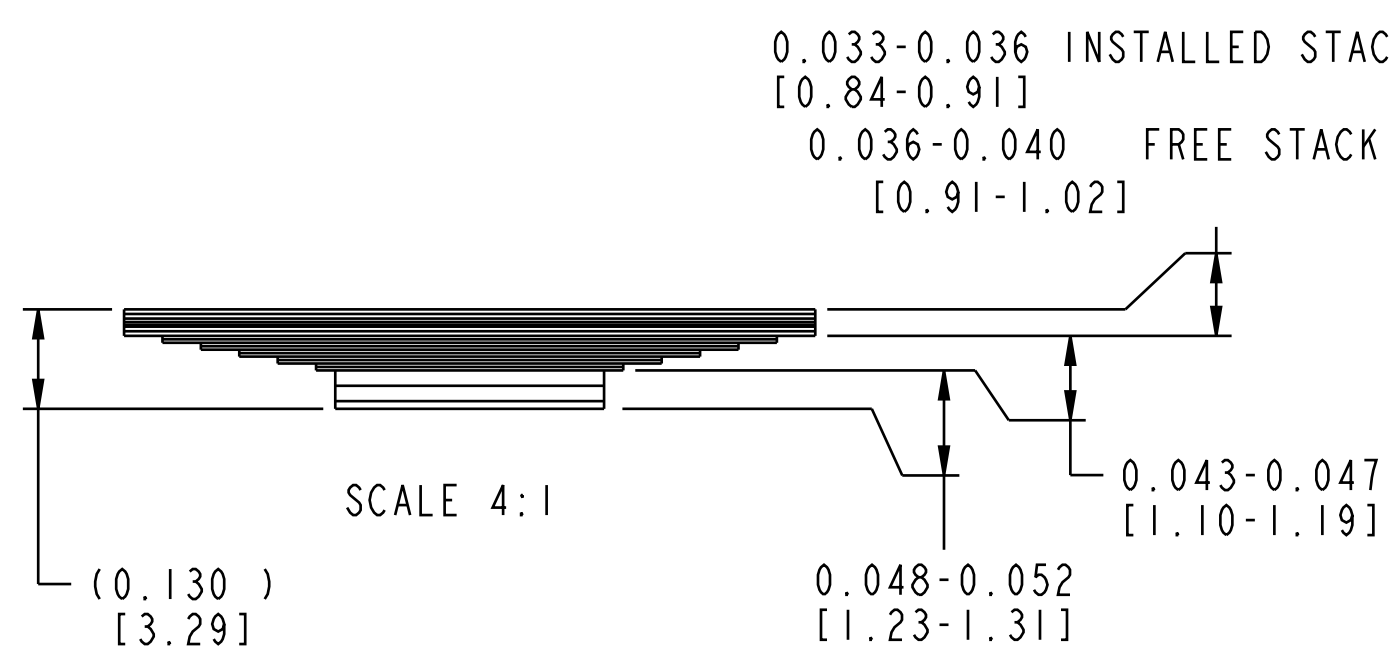

SCALE 4:1

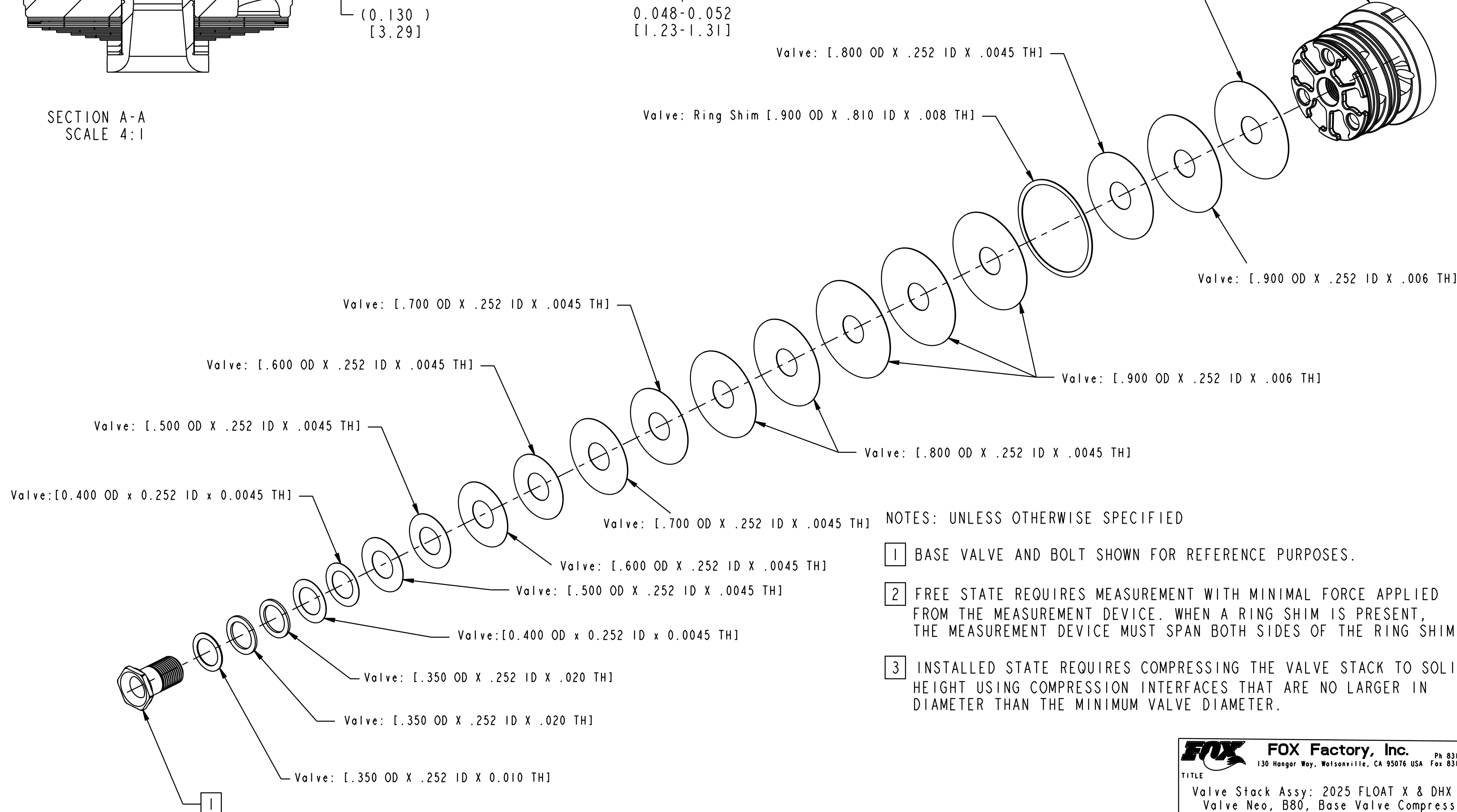

NOTES: UNLESS OTHERWISE SPECIFIED

- [1] BASE VALVE AND BOLT SHOWN FOR REFERENCE PURPOSES.
- [2] FREE STATE REQUIRES MEASUREMENT WITH MINIMAL FORCE APPLIED FROM THE MEASUREMENT DEVICE. WHEN A RING SHIM IS PRESENT, THE MEASUREMENT DEVICE MUST SPAN BOTH SIDES OF THE RING SHIM.
- [3] INSTALLED STATE REQUIRES COMPRESSING THE VALVE STACK TO SOLID HEIGHT USING COMPRESSION INTERFACES THAT ARE NO LARGER IN DIAMETER THAN THE MINIMUM VALVE DIAMETER.

PROPRIETARY
THIS DOCUMENT CONTAINS CONFIDENTIAL, PROPRIETARY INFORMATION
THAT IS FOX PROPERTY. DO NOT DISCLOSE TO OR DUPLICATE
FOR OTHERS EXCEPT AS AUTHORIZED BY FOX.

FOX		FOX Factory, Inc.	Ph 831-768-1100
130 Hangar Way, Watsonville, CA 95076 USA		Fox 831-768-9312	
TITLE Valve Stack Assy: 2025 FLOAT X & DHX Live Valve Neo, B80, Base Valve Compression			
SIZE	DWG. NO.	805-05-246-KIT	
C	PLOT SCALE 1.6:1	SHEET 1 OF 1	

4

3

2

1