

4

3

2

1

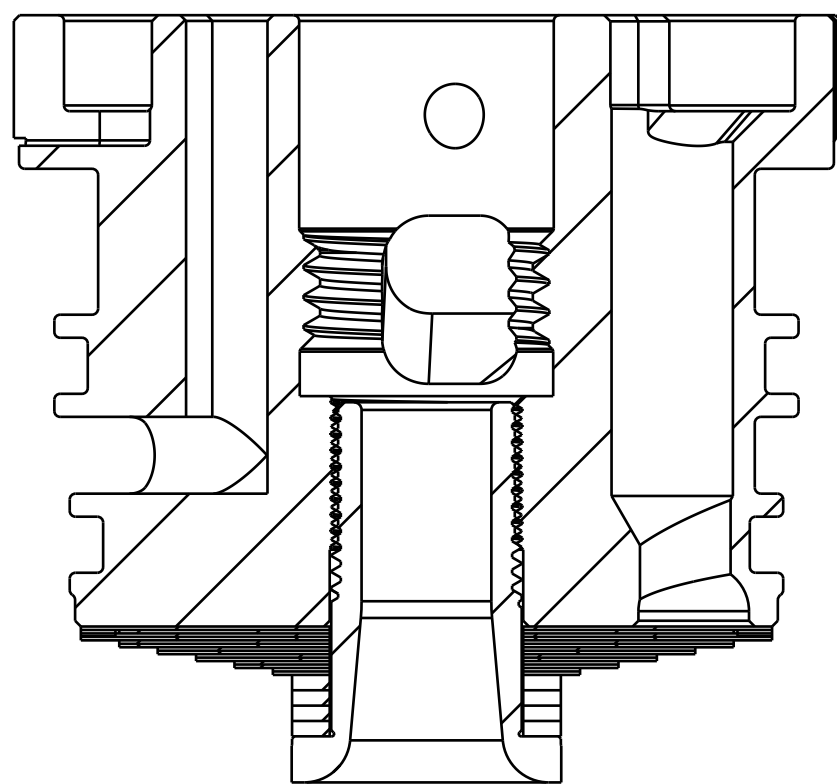

SECTION A-A  
SCALE 4:1

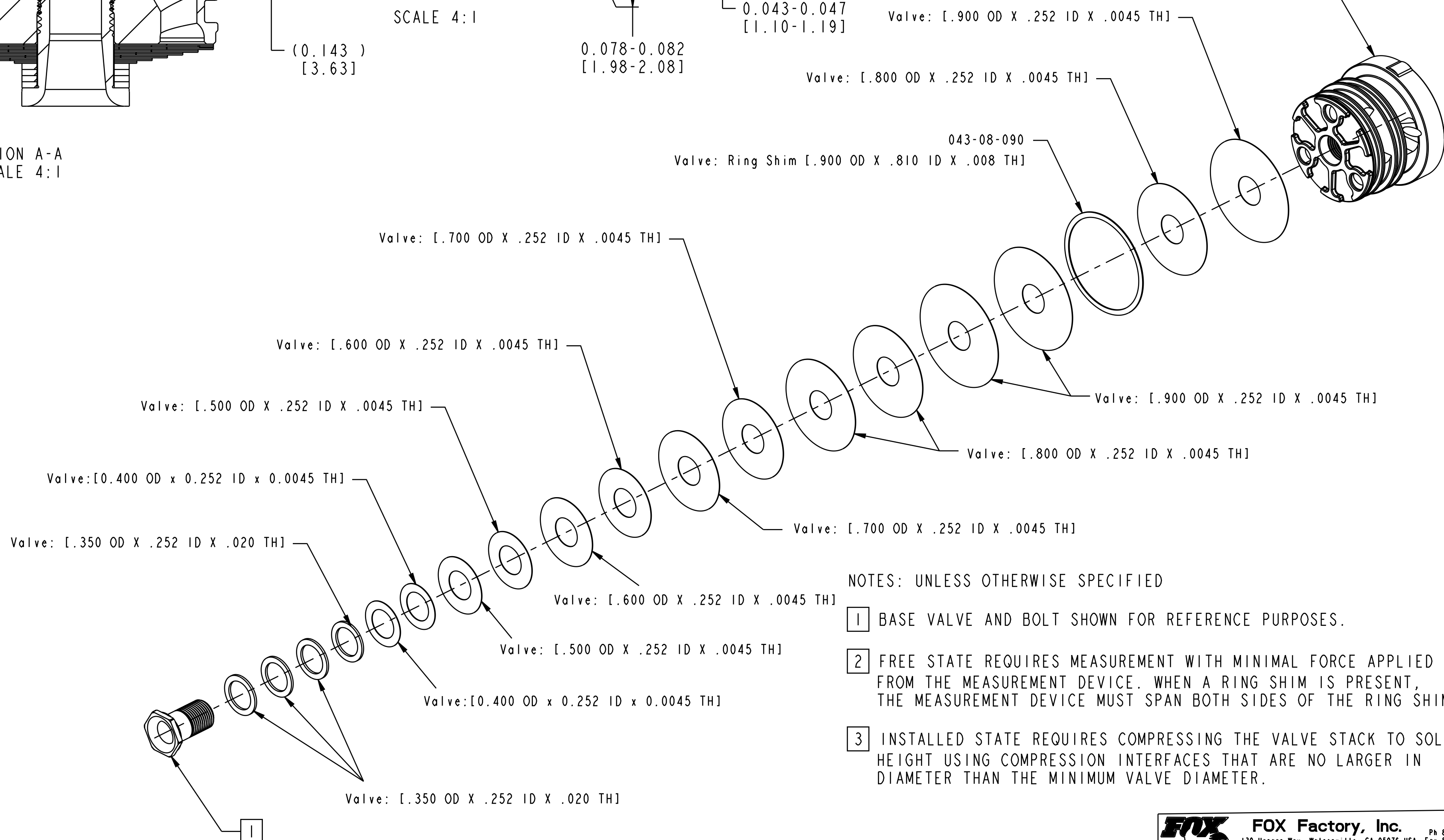
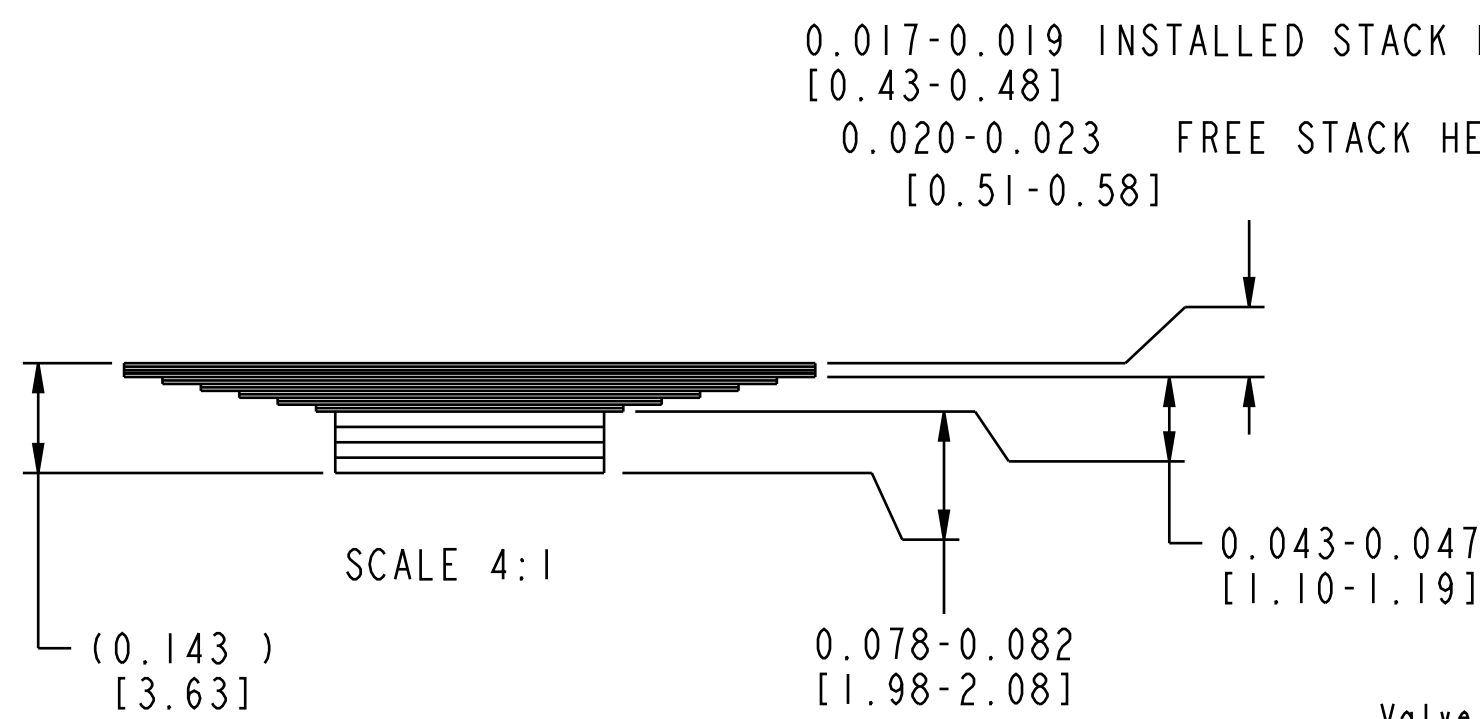

- NOTES: UNLESS OTHERWISE SPECIFIED
- [1] BASE VALVE AND BOLT SHOWN FOR REFERENCE PURPOSES.
  - [2] FREE STATE REQUIRES MEASUREMENT WITH MINIMAL FORCE APPLIED FROM THE MEASUREMENT DEVICE. WHEN A RING SHIM IS PRESENT, THE MEASUREMENT DEVICE MUST SPAN BOTH SIDES OF THE RING SHIM.
  - [3] INSTALLED STATE REQUIRES COMPRESSING THE VALVE STACK TO SOLID HEIGHT USING COMPRESSION INTERFACES THAT ARE NO LARGER IN DIAMETER THAN THE MINIMUM VALVE DIAMETER.

- PROPRIETARY -  
THIS DOCUMENT CONTAINS CONFIDENTIAL, PROPRIETARY INFORMATION  
THAT IS FOX PROPERTY. DO NOT DISCLOSE TO OR DUPLICATE  
FOR OTHERS EXCEPT AS AUTHORIZED BY FOX.

<b>FOX</b>		<b>FOX Factory, Inc.</b>		Ph 831-768-1100
130 Hangar Way, Watsonville, CA 95076 USA				Fax 831-768-9312
TITLE Valve Stack Assy: 2025 FLOAT X & DHX Live Valve Neo, B40, Base Valve Compression				
SIZE	DWG. NO.	805-05-244-KIT		
C	PLOT SCALE 1.6:1		SHEET 1 OF 1	

4

3

2

1