

Fastener, Custom (Metric): Set Screw, Dog Point, Radius, [M3 X .5mm, 9mm TLG], S

019-02-042 TORQUE: TO CAM SHAFT THEN CCW 3/8 TURN

210-26-197 Gear, Detent, Rebound 2024 Float, Gen2

GREASE: CLUMP LEVEL OF HI TEMP BLUE

010-00-005 Air Valve Parts: Core, Eaton, Low pressure

010-01-000 Ball [Ø 0.1250] Steel

GREASE: CLUMP LEVEL OF HI TEMP BLUE

010-00-057 Air Valve Parts: Cap, Air Valve [L.305-32], Black, 6061

019-01-140 Fastener: Custom (Metric): Socket Set Screw [M4 x .7mm x 3mm], SST, Patchlock

039-00-228 Spring: Detent, 2013 CTD [L.190 TLG, .088 ID, 40 lb/in] 17-7 SS

TORQUE: 6±1 IN-LB THEN BACK OFF 1 TURN

010-01-000 Ball [Ø 0.1250] Steel

039-00-264 Spring: [Ø.190 TLG X 0.120 OD X 25.6 lbs/in] 17-7 SS, left hand wound

210-26-200 Cam: (T) RD Adj, 2024 Float, 2Pos-Adj, Non Remote, Gen2

GREASE: CLUMP LEVEL OF HI TEMP BLUE

EYELET

038-00-096 Retaining Ring: External, .250 Shaft, Smalley, 2 Turn, 302 SS

Seals: O-Ring [8mm ID X 1.5mm CS] Metric, N-70, Static

210-22-625 Shim: Spring Retainer 2013 CTD (.250 ID x .370 OD x .035 TH), SS

GREASE: THIN LAYER OF SLICK HONEY OF N674-70, Dynamic

039-00-244 Spring: Barrel Wound [9 lb/in, .027 wire, .220 Free Lg] 302 SS

210-30-228 Cam: CD Adj, 2024 Float, 2Pos-Adj

.010 - .040 * [0,26 - 1,01] VALVE CORE DEPTH 100% INSPECT WITH GO/NO-GO GAGE

GREASE: CLUMP LEVEL OF HI TEMP BLUE

210-24-957 Lever: 2Pos-Adj, 2024 Float LV

210-24-956 Knob: CD Adj, 2024 Float LV, F-S

019-01-006 Fastener, Standard (Metric): Screw [M3 x 4mm] SS Socket Set Cone Point

TORQUE: 5±1 IN-LB

210-26-211 Rebound Knob: 2024 Float

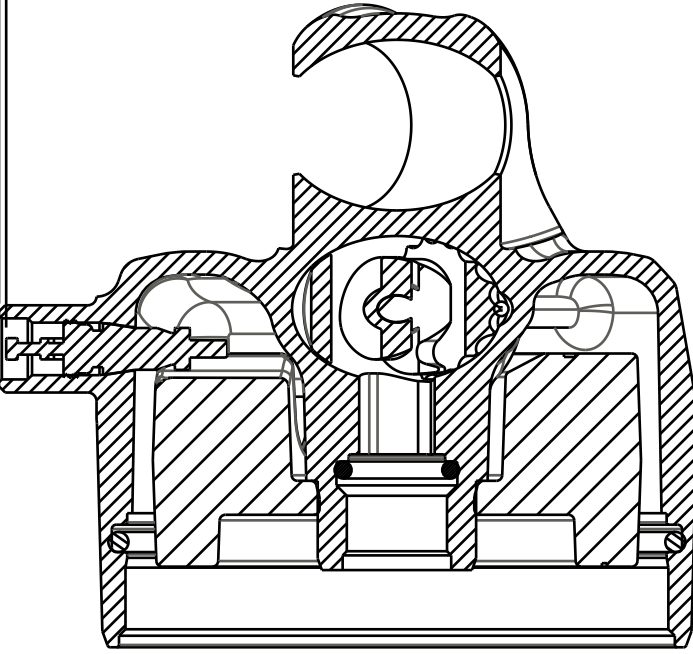

SECTION B-B

PROPRIETARY - THIS DOCUMENT CONTAINS CONFIDENTIAL, PROPRIETARY INFORMATION THAT IS FOX PROPERTY. DO NOT DISCLOSE TO OR DUPLICATE FOR OTHERS EXCEPT AS AUTHORIZED BY FOX.

FOX FOX Factory, Inc.
 Eyelet Assy: 2024, Float, 2pos-Adj, LV, Standard
 808-17-478-KIT

SIZE DWG. NO. C PLOT SCALE 1.5:1 SHEET 1 OF 1