

AIR VALVE O-RING

803-01-178  
Service Set: Air Valve Part: Housing, Tank Valve,  
DHX2, FloatX2, 2017 DPS

019-02-021  
Set Screw: Custom Dog Point, Radius [M3 x .5mm, .300 TLG], SS

TORQUE:  
TO CAM SHAFT  
AND BACK OFF 1/4 TURN

TORQUE:  
35±5 IN LB

EYELET

010-00-057  
Air Valve Parts: Cap, Air Valve [.305-32], Black, 6061

Seals: O-Ring [7.5MM ID x 1.5MM CS] Metric, N-70, Static

Spring: [0.190 TLG X 0.120 OD X 25.6 lbs/in] 17-7 SS, left hand wound

039-00-264

GREASE:  
THIN LAYER  
HIGH TEMP BLUE

EYELET O-RING

010-01-000  
Ball [Ø 0.1250] Steel

TORQUE:  
5±1 IN LB

210-30-056  
Cam: CD Adj, 2016 Float DPS, 3pos

GREASE:  
THIN LAYER  
HIGH TEMP BLUE

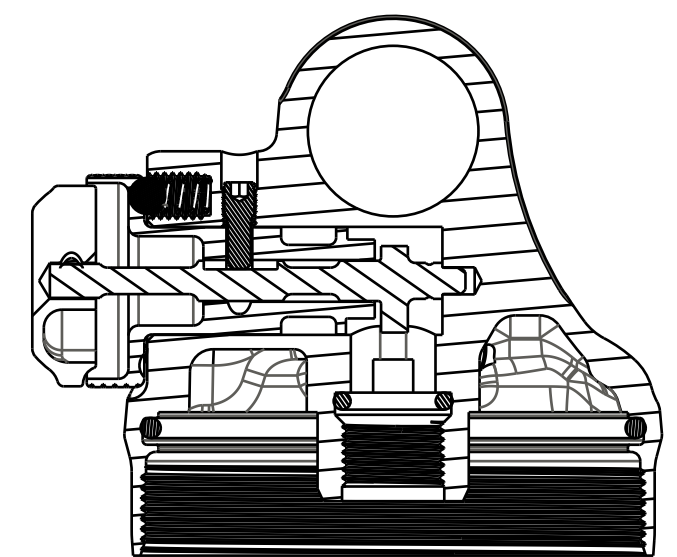

SECTION A-A

019-01-018  
Socket Set Dog Point [M3 x .5mm x 6mm]

210-26-070  
Damping Adjust Part: Lever, CD, 2024 Float SV, 3-Pos

210-30-044  
Damp Adj Part: Knob, RD Adj, 2013 FLOAT CTD Perf And Evol

NOTES:

1 APPLY A THIN LAYER OF SLICK HONEY TO INSTALL ON AIR VALVE.  
APPLY A THNIN LAYER OF FLOAT FLUID ON INSTALLED AIR VALVE  
O-RING PRIOR TO AIR VALVE INSTALLATION.

PROPRIETARY  
THIS DOCUMENT CONTAINS CONFIDENTIAL, PROPRIETARY INFORMATION  
THAT IS FOX PROPERTY. DO NOT DISCLOSE TO OR DUPLICATE  
FOR OTHERS EXCEPT AS AUTHORIZED BY FOX.

TITLE	<b>FOX Factory, Inc.</b>		Ph 831-768-1100
	130 Hangar Way, Watsonville, CA 95076 USA		Fax 831-768-9312
Eyelet Assy: 2025, Rhythm LV, 2-pos, Trunnion			
SIZE	DWG. NO.	808-17-656-KIT	
C	PLOT SCALE   .50:1		SHEET 1 OF 2