

4

3

2

1

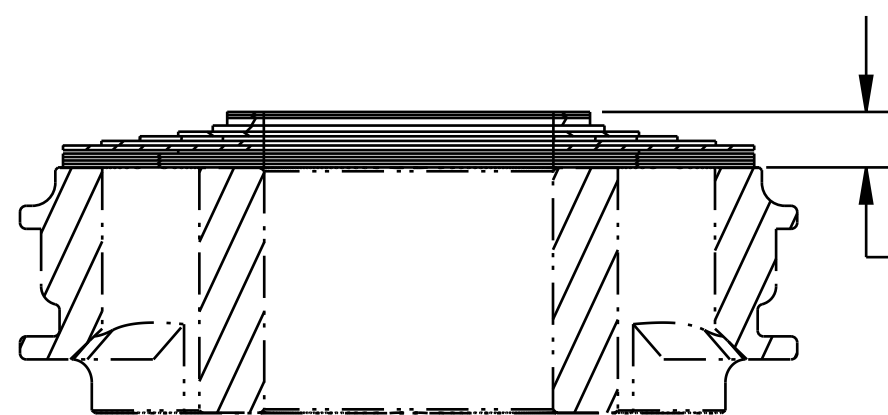

SECTION A-A
SCALE 4:1

.069-.075 [1,76-1,91] 3

Valve: Metric [12.0 mm OD X 9.58mm ID X 0.10mm TH]
Valve: Metric [12.0 mm OD X 9.58mm ID X 0.10mm TH]

Valve: Metric [12.0 mm OD X 9.58mm ID X 0.25mm TH]

Valve: [.510 OD X .377 ID X .008 TH]

Valve: [.600 OD X .377 ID X .006 TH]

Valve: [.700 OD X .377 ID X .006 TH]

Valve: [.800 OD X .377 ID X .006 TH]

Valve: [.900 OD X .377 ID X .006 TH]

Valve: [.600 OD X .377 ID X .0045 TH]

Valve: [.900 OD X .377 ID X .0045 TH]

Valve: [.900 OD X .377 ID X .0045 TH]

Valve: [.900 OD X .377 ID X .0045 TH]

Valve: [.900 OD X .377 ID X .0045 TH]

MAIN PISTON ASSY 1

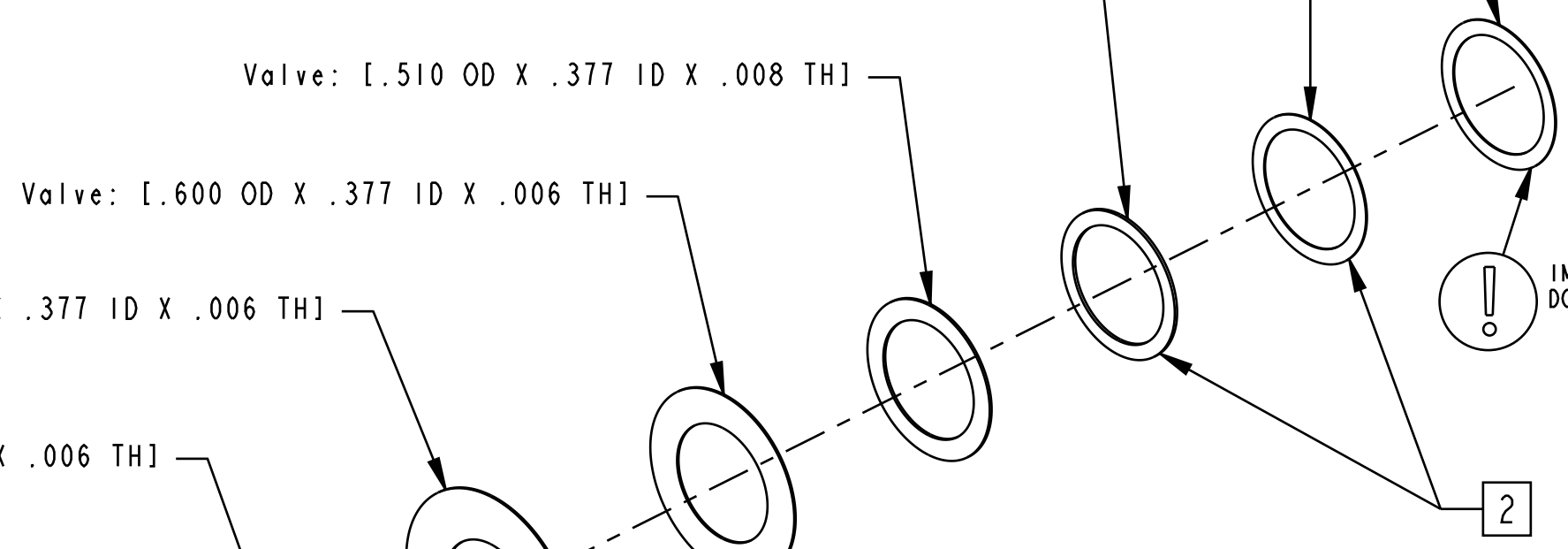

IMPORTANT:
DO NOT REMOVE

2

MANUFACTURING NOTES:

1 MAIN PISTON ASSEMBLY SHOWN FOR ORIENTATION PURPOSES. NOTE PROPER ORIENTATION OF PISTON--SEE VALVING ASSEMBLY DRAWING FOR DETAILS. IMAGE SHOWN MAY NOT REPRESENT ACTUAL PART GEOMETRY.

2 INDICATED SPACERS MAY BE ADDED OR REMOVED TO ADJUST NUMBER OF REBOUND CLICKS.

3 DIMENSION APPLIES TO VALVE STACK AS SHOWN.

DESIGN ENGINEERING AND PRODUCT PERFORMANCE NOTES:

4. COMPRESSION VALVE STACK NOMINAL MINIMUM THICKNESS (NMT): 0.059 [1,50]

FOX FOX Factory, Inc. Ph 831-768-1100
130 Hangar Way, Watsonville, CA 95076 USA Fax 831-768-9312

TITLE
Valve Stack Assy: 2025 FLOAT X & DHX, CS70, Comp Split Stack, FP, .059 NMT

SIZE DWG. NO. **C** 805-05-716-KIT

PLOT SCALE 2:1 SHEET 1 OF 1

PROPRIETARY - THIS DOCUMENT CONTAINS CONFIDENTIAL, PROPRIETARY INFORMATION THAT IS FOX PROPERTY. DO NOT DISCLOSE TO OR DUPLICATE FOR OTHERS EXCEPT AS AUTHORIZED BY FOX.

4

3

2