

4

3

2

1

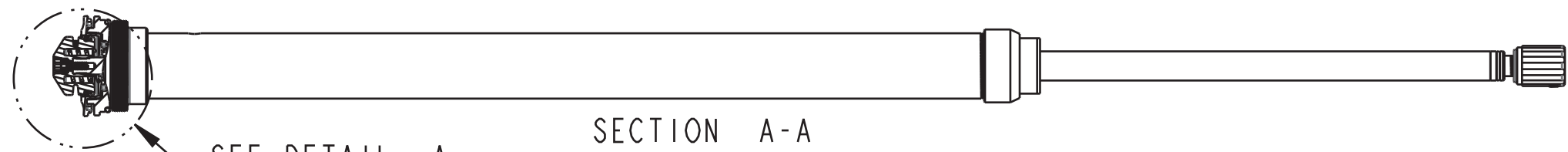

SEE DETAIL A

SECTION A-A
SCALE 1:2

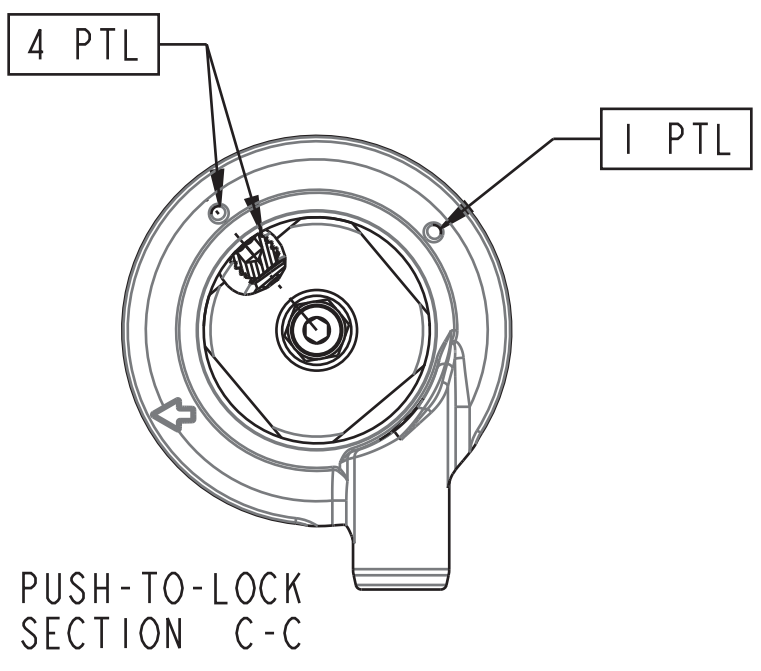

PUSH-TO-LOCK
SECTION C-C

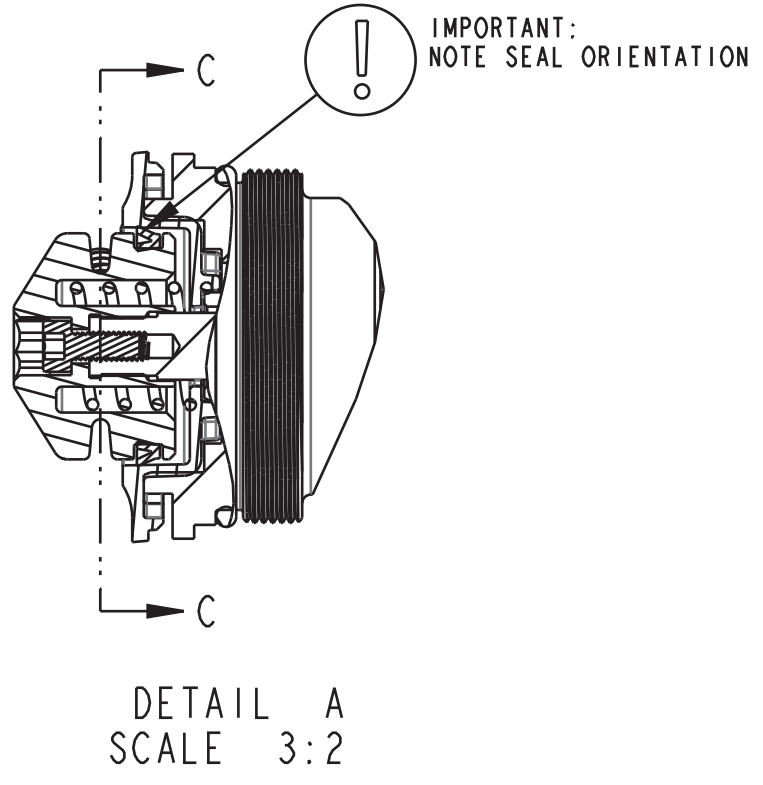

DETAIL A
SCALE 3:2

IMPORTANT:
NOTE SEAL ORIENTATION

Fastener, Standard: Screw [#8-32 X 0.250 TLG]

TORQUE:
150±7
(IN-LB)

REFERENCE ONLY
(FOR INSTALLATION
INTO FORK)

LOCTITE:
BLUE 243, ONE DROP
APPLY PER 605-14-175-01

TORQUE:
5.0±0.5 IN.LB.

REBOUND KNOB

241-00-011
Fastener, Custom: Nut, Bottom, R

820-05-328-KIT
2017 34 27.5 and 29in Grip Bottom Stud Interface Parts

241-01-011
Fastener, Custom: Crush Washer, Plastic, 13mm

TOPCAP INTERFACE PARTS INSTALL NOTES:

PUSH-TO-LOCK (PTL):

- 1 PTL SUB-ASSEMBLE TOPCAP INTERFACE PARTS WITH PULLEY SET SCREW FACING THE DOT OPPOSITE THE ARROW.
2. INSTALL 1 PTL SUB-ASSY TO DAMPER WITH ARROW FACING DESIRED DIRECTION FOR CABLE ROUTING. TIGHTEN SCREW 2-3 TURNS (DO NOT RUN DOWN).
3. ROTATE ENTIRE SUB-ASSY 270° CCW AFTER INSTALLING. CHECK CABLE DIRECTION. TORQUE SCREW WHILE HOLDING PULLEY
- 4 PTL WHEN LOCKED OUT (ADD 5-6 IN-LB CW TORQUE TO PULLEY), SET SCREW MUST BE ALIGNED TO MARK ±20°.
5. PULLEY MUST RETURN FREELY AFTER LOCKOUT (FROM FORCE OF TORSION SPRING ALONE).

TORQUE: PUSH-TO-LOCK & PUSH-TO-UNLOCK:
NEEDLE TO 2.0 ± .15 IN-LB BEFORE
INSTALLING TOPCAP INTERFACE PARTS
(SAME TORQUE FOR CARTRIDGE DYNO)

REFERENCE ONLY
(FOR INSTALLATION
INTO FORK)

TORQUE:
220±5 IN.LB.

TORQUE:
(10±1 IN.LB)
REF: FOR BIKE INSTALL

TORQUE:
6±1 IN.LB.

GREASE:
THIN LAYER BLUE MARINE GREASE
ID AND OD

Seals: U-Cup, Shore 70A, 2013 CTD-ADJ, Remote Fit-CTD and Remote O/C-CTD

Fastener: Custom (Metric): Set Screw [M4 x .7mm x 3mm] SST, Patchlock

Cable Pulley Remote, 2020 GRIP

Fastener Standard (Metric): Screw [M2.5X8mm] Socket Head Cap, SS

CABLE HOUSING

820-05-611-KIT
2020 Grip Push-Lock Remote, Topcap Interface Parts

TORSION SPRING

FOX FOX Factory, Inc. Ph 831-768-1100
130 Hangar Way, Watsonville, CA 95076 USA Fax 831-768-9312

TITLE
2025 34 27.5 & 29 130-160, Grip
Push-Lock Remote Cart Assy Complete

SIZE DWG. NO. **C** 820-18-565-KIT

PLOT SCALE ~1:1 SHEET 1 OF 1

PROPRIETARY
THIS DOCUMENT CONTAINS CONFIDENTIAL, PROPRIETARY INFORMATION
THAT IS FOX PROPERTY. DO NOT DISCLOSE TO OR DUPLICATE
FOR OTHERS EXCEPT AS AUTHORIZED BY FOX.

4

3

2

1

ProE ASSEM