

SECTION A-A

- Damping Adj Part: Coupler, LSC, Grip2 210-24-245
- Retaining Ring: Wire [.280 OD X .024 CS] SS 038-01-073
- Seals: O-Ring [3.0MM ID x 1.5MM CS] Metric, N-70, Static 029-08-068
- HSC Coupler, Remote, 2025 GRIP X 210-26-285
- Seals: O-Ring [5.0MM ID x 1.5MM CS] Metric, N-70, Static 029-08-012
- Seals: O-Ring [(-011) .070 C.S. X .301 ID] Standard, N-70, Static
- Piston: Floating: 24mm Bore, 2024 Grip3
- Damping Adj Part: Valve, LSC, 2025 Grip X
- Damping Adj Part: HSC Adjust, Hat, 2025 GRIP X
- Valve: Metric [10.1mm ID X 15.0mm OD X 0.10 TH]
- Spring Perch, 2025 Grip X, Med 820-03-728-KIT
- Valve Stack Assy: 2025 GRIP X, Compression Firm, CF
- Piston, Damping, BV, 2-Wing, 2025 GRIP X, CNC, 24 Bore
- Seals: O-Ring [21.0 MM ID x 1.5 MM CS] Metric, N-70, Static
- Valve: [.800 OD X .330 ID X .010 THK] Custom, Check
- Spring: Conical, LIVE Shock, Check [1.25TLG, 1.75 lbf/in, .32in ID X .65in OD], 302 SS
- Fastener, Custom (Metric): Bolt, Piston, [.25-48 X 9.4mm TLG], 2024 Grip3

WHEN PRESSING SHAFT TO TOPCAP, PRESS ON THIS SURFACE ONLY \*

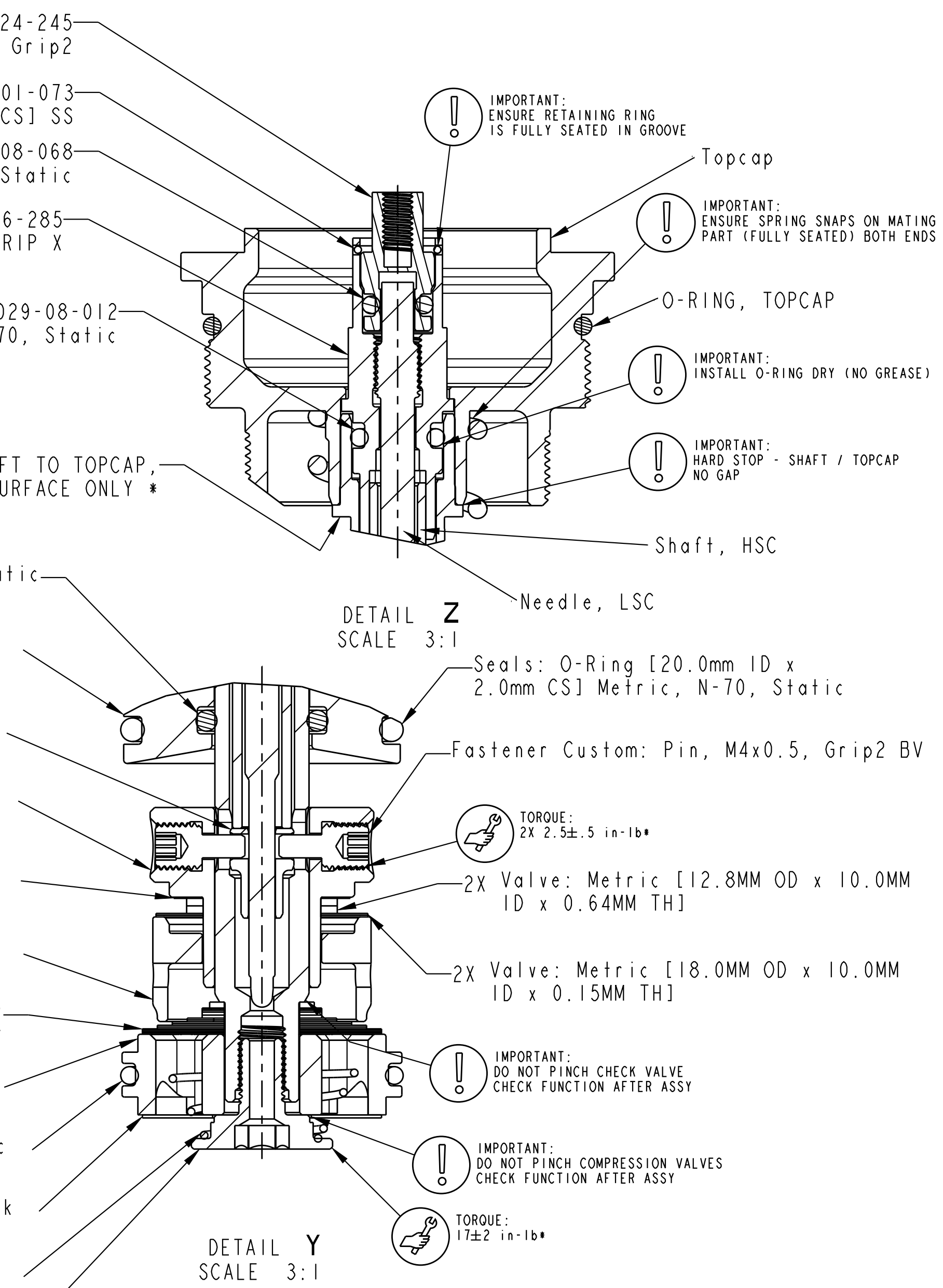

DETAIL Z SCALE 3:1

DETAIL Y SCALE 3:1

- IMPORTANT: ENSURE RETAINING RING IS FULLY SEATED IN GROOVE
- Topcap
- IMPORTANT: ENSURE SPRING SNAPS ON MATING PART (FULLY SEATED) BOTH ENDS
- O-RING, TOPCAP
- IMPORTANT: INSTALL O-RING DRY (NO GREASE)
- IMPORTANT: HARD STOP - SHAFT / TOPCAP NO GAP
- Shaft, HSC
- Needle, LSC

TORQUE: 2X 2.5±.5 in-lb\*

IMPORTANT: DO NOT PINCH CHECK VALVE CHECK FUNCTION AFTER ASSY

IMPORTANT: DO NOT PINCH COMPRESSION VALVES CHECK FUNCTION AFTER ASSY

TORQUE: 17±2 in-lb\*

- PROPRIETARY - THIS DOCUMENT CONTAINS CONFIDENTIAL, PROPRIETARY INFORMATION THAT IS FOX PROPERTY. DO NOT DISCLOSE TO OR DUPLICATE FOR OTHERS EXCEPT AS AUTHORIZED BY FOX.

<b>FOX</b> FOX Factory, Inc. Ph 831-768-1100 130 Hangar Way, Watsonville, CA 95076 USA Fax 831-768-9312	
TITLE	2025 34 140, GRIP X, Topcap Assy, Remote
SIZE DWG. NO.	C 820-05-762-KIT
PLOT SCALE	1.5:1 SHEET 1 OF 3