

4

3

2

1

D

D

C

C

B

B

A

A

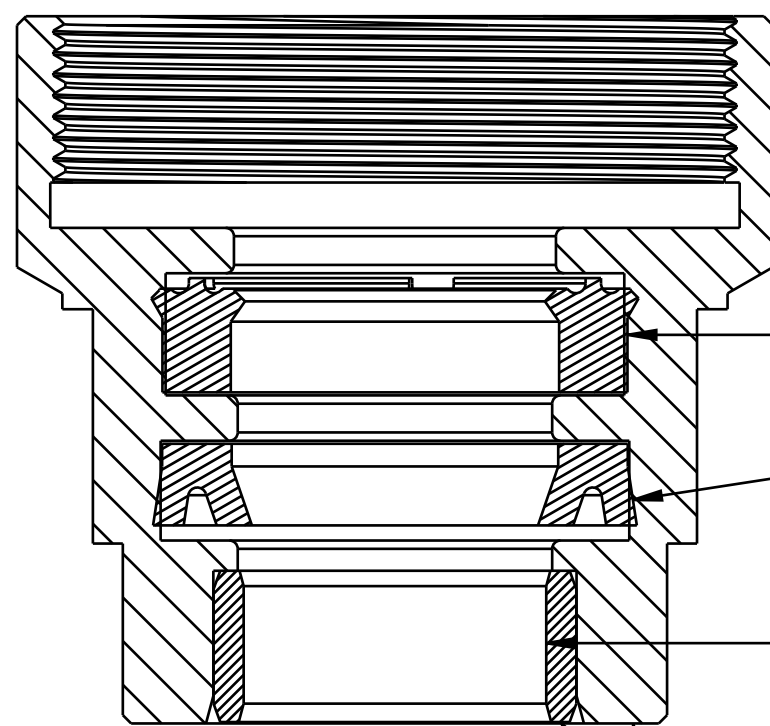

! IMPORTANT:  
ORIENTATION OF SEAL IS CRITICAL-  
SEAL LIPS FACE CARTRIDGE

! IMPORTANT:  
ORIENTATION OF SEAL IS CRITICAL-  
SEAL LIPS FACE LOWER LEG

! IMPORTANT:  
BUSHING ID AFTER INSTALLATION INTO HOUSING IS CRITICAL-  
100% SIZE BUSHING FOR GOOD SLIDING FIT WITH MATING COMPONENT (10MM SHAFT)

! IMPORTANT:  
PRESS BUSHING FLUSH BELOW THIS SURFACE

SECTION B-B

Seals: Scraper, 2020 Marzocchi Z2 Damper Shaft

Seals: U-Cup, 10mm Shaft

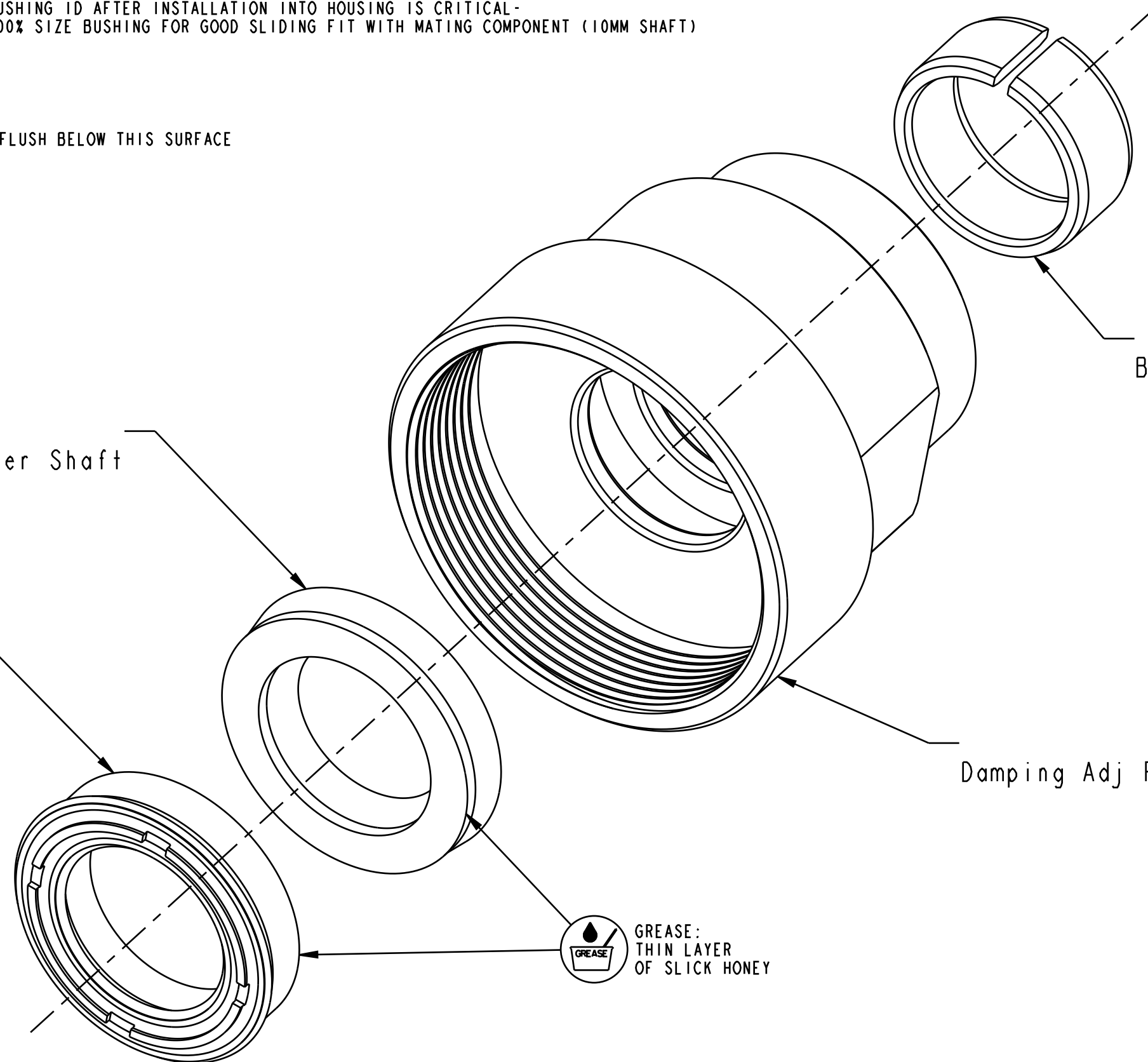

Bearing Internal: 10mm ID X 12mm OD X 5mm THK

Damping Adj Part: Bearing Housing, Dual, Rail 2.0

GREASE:  
THIN LAYER  
OF SLICK HONEY

- PROPRIETARY -  
THIS DOCUMENT CONTAINS CONFIDENTIAL, PROPRIETARY INFORMATION  
THAT IS FOX PROPERTY. DO NOT DISCLOSE TO OR DUPLICATE  
FOR OTHERS EXCEPT AS AUTHORIZED BY FOX.

**FOX** FOX Factory, Inc. Ph 831-768-1100  
130 Hangar Way, Watsonville, CA 95076 USA Fax 831-768-9312

TITLE 2025 34/36 Rail 2.0, All,  
Bearing Housing Assy

SIZE DWG. NO. C 820-03-695-KIT

PLOT SCALE 4:1 SHEET 1 OF 1

4

3

2

ProE ASSEM