

4

3

2

1

ALIGN 3X FEATURES WITH FLATS OR PEAK OF TOPCAP

ENGAGE 2X FEATURES

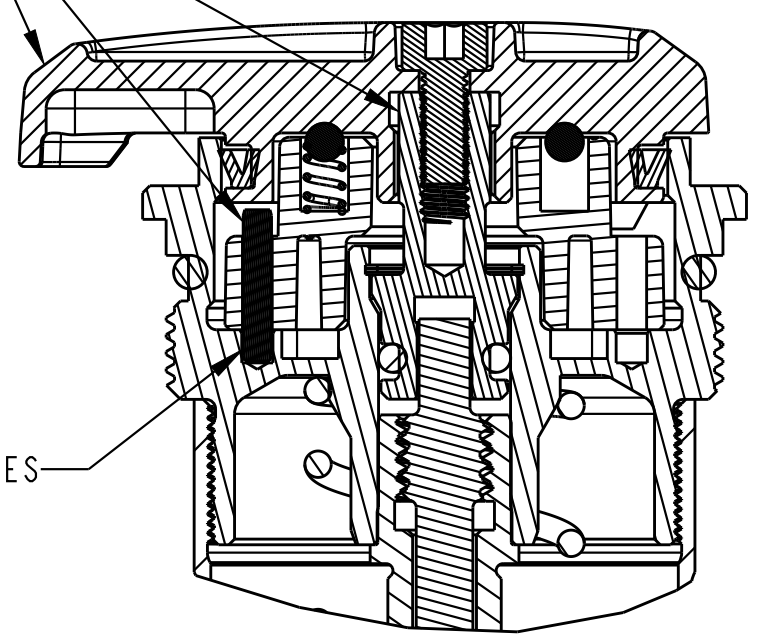

SECTION A-A  
SCALE 2.500

241-00-005  
Fastener, Custom: Nut, Bottom, R-RL-RLC

241-01-002  
Fastener, Custom: Crush Washer, Plastic, R-RL-RLC

TORQUE:  
50±5 IN LBS

820-05-705-KIT  
2022 34SC Bottom Stud Interface Parts, All Dampers

Spring: Detent [.138 TLG, .087 OD, 48 lb/in]

Air Valve Parts: Ball [2.0mm OD], Grade 25 Steel, Chrome Plated

GREASE:  
THIN LAYER OF SLICK HONEY

TORQUE:  
4±1 IN LBS

IMPORTANT:  
ADJUSTER SET TO FIRM POSITION  
32±2.4 OZ-IN

2025 34 SC 120, GRIP SL, 3 Pos Adj, Cart Assy

820-05-731-KIT  
2025 GRIP-SL Topcap Interface Parts, Blue Ano

Damper Adjust Part: Detent, Molded, 2025 GRIP SL

Pin: Dowel [1.5mm OD x 8mm TLG] SST

Spring: Detent [.138 TLG, .087 OD, 48 lb/in]

Air Valve Parts: Ball [2.0mm OD], Grade 25 Steel, Chrome Plated

Seals: U-Cup, Shore 70A, 2013 Fit-CTD and CTD-ADJ

Knob, Lockout Selector, 2025 GRIP SL

Fastener Standard (Metric): Screw, Socket Head, M2.5 X 6

**FOX** FOX Factory, Inc. Ph 831-768-1100  
130 Hangar Way, Watsonville, CA 95076 USA Fax 831-768-9312

TITLE  
2025 34 SC 120, GRIP SL,  
3 Pos Adj, Cart Assy Complete

SIZE DWG. NO.  
C | 820-18-504-KIT

PLOT SCALE 1:1 SHEET 1 OF 2

- PROPRIETARY -  
THIS DOCUMENT CONTAINS CONFIDENTIAL, PROPRIETARY INFORMATION  
THAT IS FOX PROPERTY. DO NOT DISCLOSE TO OR DUPLICATE  
FOR OTHERS EXCEPT AS AUTHORIZED BY FOX.

4

3

2

ProE ASSEM