

*ASSEMBLY INSTRUCTIONS:

- 1) TIGHTEN VVC NUT (241-00-067) UNTIL VVC LEAF SPRING (043-XX-650) MAKES CONTACT WITH POSTS ON VVC PLATE (050-00-XXX) AND ROTATION STOPS
- 2) ORIENT VVC LEAF SPRING TO THE APPROX. CENTER OF ITS ADJUSTMENT RANGE
- 3) PLACE .050 [1,27] THICK SHIM AT "X"
- 4) HOLD VVC NUT TO PISTON ASSY AND TORQUE HSR SHAFT TO $2 \pm .5$ in-lb
- 5) TORQUE M3 SHCS (019-01-095) TO SPECIFIED TORQUE

TORQUE:
 40 ± 5 IN. LB.

SECTION A-A
SCALE 4:1

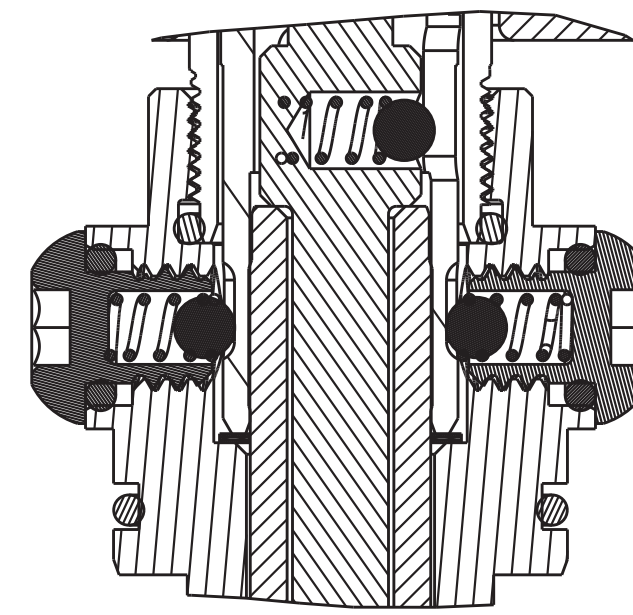

SECTION A-A
SCALE 4:1

820-03-572-KIT
2019 40 203, Grip2 HSR, 2-Piece Damper Shaft Assy

Valve: Metric [8mm OD X 6mm ID X 0.10mm THK]

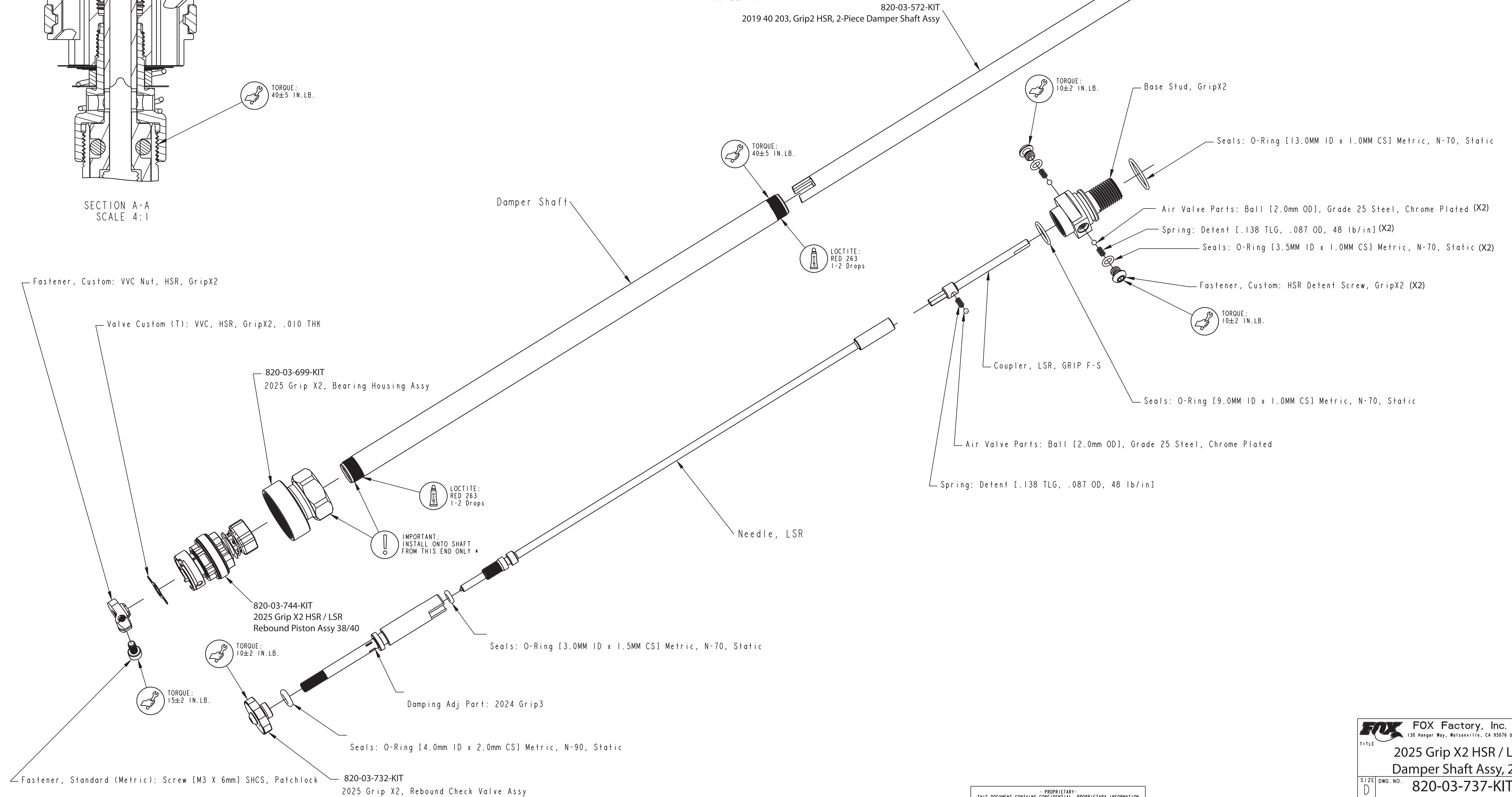

PROPRIETARY - PROPRIETARY INFORMATION
THIS DOCUMENT CONTAINS CONFIDENTIAL, PROPRIETARY INFORMATION
THAT IS FOR PROPERTY. DO NOT DISCLOSE TO OR DUPLICATE
FOR OTHERS EXCEPT AS AUTHORIZED BY FOX.

FOX FOX Factory, Inc. Ph 831-768-1100
130 Hangar Way, Watsonville, CA 95076 USA Fax 831-768-9312

TITLE
**2025 Grip X2 HSR / LSR
Damper Shaft Assy, 203**

SIZE DWG. NO. **820-03-737-KIT**

PLOT SCALE | 1.25:1 | SHEET 1 OF 2