

4

3

2

1

***ASSEMBLY INSTRUCTIONS:**

- 1) ORIENT LEAF SPRING TO THE APPROX. CENTER OF ITS ADJUSTMENT RANGE
- 2) ENGAGE FLATS OF LEAF SPRING TO RBD NUT
- 3) PLACE .030 [0,76] THICK SHIM AT "X"
- 4) HOLD RBD NUT TO PISTON ASSY AND TORQUE HSR SHAFT TO $2 \pm .5$ in-lb
- 5) ROTATE HSR SHAFT CCW 4 CLICKS (72°)
- 6) TORQUE M2 SHCS (019-01-141) TO SPECIFIED TORQUE

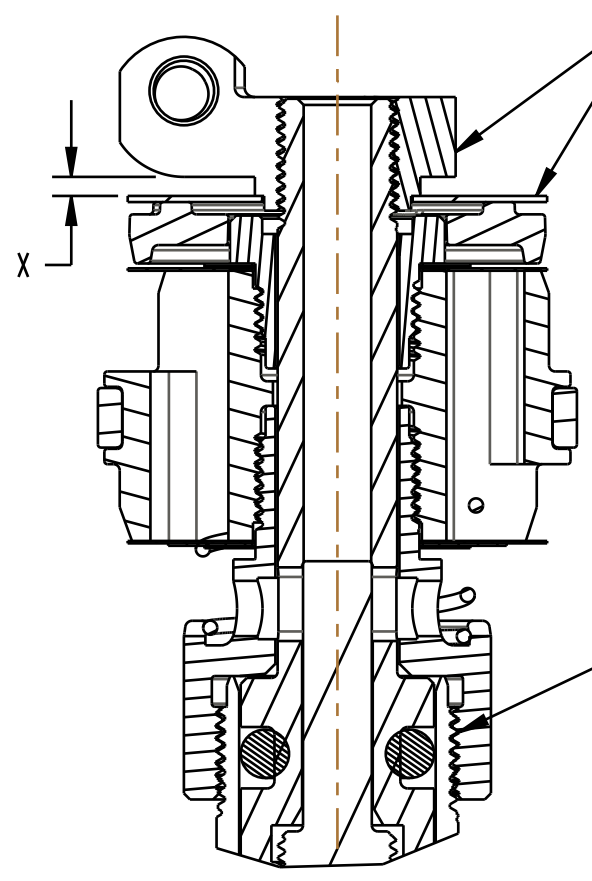

SECTION D-D

TORQUE:
 40 ± 5 in-lb*

Seals: O-Ring [3.0MM ID x 1.0MM CS] Metric, N-70, Static

Valve: Metric
[8.00mm OD X 6mm ID X 0.10mm THK]

Fastener, Custom: Screw [#8-32] SHCS

Seals: O-Ring [13.0MM ID x 1.0MM CS] Metric, N-70, Static

Fastener Standard (Metric): Screw [M2.5 X 6mm] Tapered Head Cap, Steel, Black

LOCTITE:
RED 263
1-2 DROPS

Spring: Detent [.138 TLG, 087 OD 48 lb/in]

Fastener, Custom: Nut, HSR, Grip F-S

Spring, Leaf, HSR, Grip F-S, .010 THK

Plate, HSR, Grip F-S

Air Valve Parts: Ball [2.0mm OD], Grade 25 Steel, Chrome Plated

REBOUND PISTON ASSEMBLIES:
820-03-717-KIT: 2024 Grip2 HSR / LSR Rebound Piston Assy
820-03-721-KIT: 2024 Grip2 HSR / LSR Rebound Light Piston Assy

Seals: O-Ring [9.0MM ID x 1.0MM CS] Metric, N-70, Static

TORQUE:
 40 ± 5 in-lb*

Coupler, LSR, Grip F-S

Air Valve Parts: Ball [2.0mm OD], Grade 25 Steel, Chrome Plated

Spring: Detent [.138 TLG, 087 OD 48 lb/in]

Damper Shaft

Needle, LSR

IMPORTANT:
INSTALL ONTO SHAFT FROM THIS END ONLY *

LOCTITE:
RED 263
1-2 DROPS

820-03-525-KIT
2019 Grip2 Bearing Housing Assy

Seals: O-Ring [3.0MM ID x 1.5MM CS] Metric, N-70, Static

Adjuster, HSR, Grip F-S

TORQUE:
 $8 \pm .5$ in-lb

Seals: O-Ring [4.0mm ID x 2.0mm CS] Metric, N-90 Static

PROPRIETARY - THIS DOCUMENT CONTAINS CONFIDENTIAL, PROPRIETARY INFORMATION THAT IS FOX PROPERTY. DO NOT DISCLOSE TO OR DUPLICATE FOR OTHERS EXCEPT AS AUTHORIZED BY FOX.

		FOX Factory, Inc.	Ph 831-768-1100
		130 Hangar Way, Watsonville, CA 95076 USA	Fax 831-768-9312
TITLE			
2024 38 VVC HSR/LSR DAMPER SHAFT ASSEMBLIES			
SIZE DWG. NO.			
C			
PLOT SCALE		1:1	SHEET 1 OF 2

4

3

2

ProE ASSEM