

4

3

2

1

- *ASSEMBLY INSTRUCTIONS:**
- 1) ORIENT LEAF SPRING TO THE APPROX. CENTER OF ITS ADJUSTMENT RANGE
 - 2) ENGAGE FLATS OF LEAF SPRING TO RBD NUT
 - 3) PLACE .030 [0,76] THICK SHIM AT "X"
 - 4) HOLD RBD NUT TO PISTON ASSY AND TORQUE HSR SHAFT TO $2 \pm .5$ in-lb
 - 5) ROTATE HSR SHAFT CCW 4 CLICKS (72°)
 - 6) TORQUE M2 SHCS (019-01-141) TO SPECIFIED TORQUE

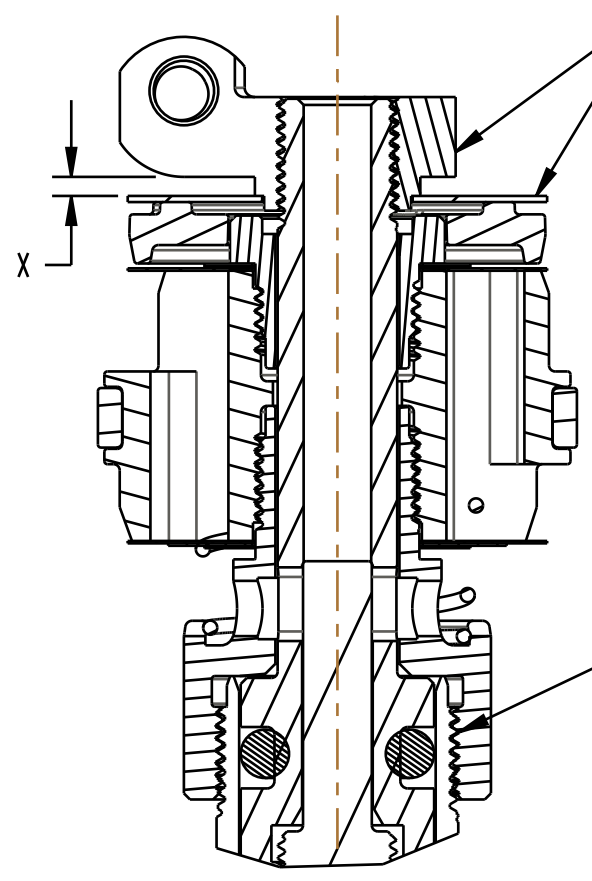

SECTION D-D

Valve: Metric
[8.00mm OD X 6mm ID X 0.10mm THK]

Seals: O-Ring [3.0MM ID x 1.0MM CS] Metric, N-70, Static

Fastener, Custom: Screw [#8-32] SHCS

Seals: O-Ring [13.0MM ID x 1.0MM CS] Metric, N-70, Static

Fastener Standard (Metric): Screw [M2.5 X 6mm] Tapered Head Cap, Steel, Black

LOCTITE: RED 263 1-2 DROPS

Spring: Detent [.138 TLG, 087 OD 48 lb/in]

Fastener, Custom: Nut, HSR, Grip F-S

Spring, Leaf, HSR, Grip F-S, .010 THK

Air Valve Parts: Ball [2.0mm OD], Grade 25 Steel, Chrome Plated

Base Stud, Grip F-S

Plate, HSR, Grip F-S

820-03-655-KIT
2021 Grip2 VVC HSR / LSR Rebound Piston Assy Long Travel

TORQUE: 40±5 in-lb*

Seals: O-Ring [9.0MM ID x 1.0MM CS] Metric, N-70, Static

Coupler, LSR, Grip F-S

Air Valve Parts: Ball [2.0mm OD], Grade 25 Steel, Chrome Plated

Damper Shaft

Spring: Detent [.138 TLG, 087 OD 48 lb/in]

LOCTITE: RED 263 1-2 DROPS

IMPORTANT: INSTALL ONTO SHAFT FROM THIS END ONLY *

Needle, LSR

820-03-525-KIT
2019 Grip2 Bearing Housing Assy

Seals: O-Ring [3.0MM ID x 1.5MM CS] Metric, N-70, Static

Adjuster, HSR, Grip F-S

TORQUE: 8±.5 in-lb

Seals: O-Ring [4.0mm ID x 2.0mm CS] Metric, N-90 Static

PROPRIETARY - THIS DOCUMENT CONTAINS CONFIDENTIAL, PROPRIETARY INFORMATION THAT IS FOX PROPERTY. DO NOT DISCLOSE TO OR DUPLICATE FOR OTHERS EXCEPT AS AUTHORIZED BY FOX.

		FOX Factory, Inc.	Ph 831-768-1100
		130 Hangar Way, Watsonville, CA 95076 USA	Fax 831-768-9312
TITLE			
2021 36 180, Grip2 VVC HSR / LSR Damper Shaft Assy			
SIZE	DWG. NO.	820-03-662-KIT	
C			
PLOT SCALE		1:1	SHEET 1 OF 2

4

3

2

ProE ASSEM